

Air Cooling Dry Vacuum Pump

NeoDry-G Series

Operating Manual

Applicable models

NeoDry7G/NeoDry15G/NeoDry30G/NeoDry36G

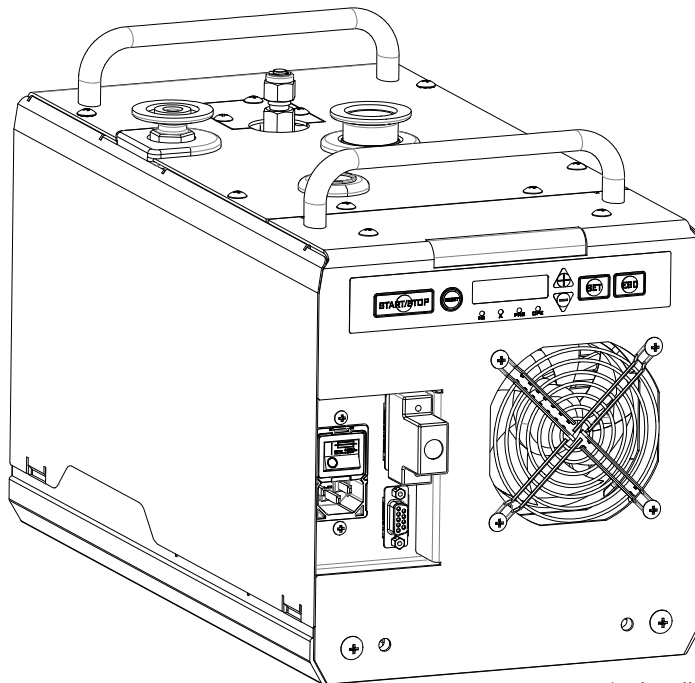

* This illustration is a NeoDry15G.

- This operating manual explains the installation, operation, maintenance and inspection of the air-cooled dry vacuum pump.
- Before installing, operating, inspecting and maintaining the pump, be sure to read through this operating manual for correct use.
- This operating manual provides important information for operating the air-cooled dry vacuum pump.

Keep this in a place where users can refer to it at any time.

Important Notice

Purpose of use and use application

The air-cooled dry vacuum pump (hereinafter referred to as the "Pump") is an industrial vacuum source used for vacuum exhaust, vacuum state retaining, and the situations where clean environment is desired.

Do not use it for any purposes other than above. Because applications using radiation could affect the pumps, the pump used under the influence of radiation prevents it from being repaired and will not be covered by this warranty.

When operating the Pump:

- Observe all laws and regulations of national and local government authorities.
- Kashiyama Industries, Ltd. (hereinafter referred to as "Kashiyama") is unable to predict all dangers existing in the Pump, those caused by human error, and those resulting from the operating environment of the Pump. It is, therefore, necessary to pay attention not only to the precautions provided in this operating manual but also the generally-practiced safety measures when handling the Pump.

Operator:

- Only persons appointed by the administrator or those who satisfy the following conditions are allowed to operate the Pump.
 - (a) Persons who have read and fully understand this operating manual and drawings.
 - (b) Persons who have successfully completed on-site training provided by the employer, understand operational details and are capable of operation.
 - (c) Persons in good health.
(Do not allow persons in poor health, or those with health issues, including hyperpiesia, to operate the Pump)

About this operating manual

- The programs and operating manual related to the Pump are protected by the copyright law. Therefore, duplicating, reprinting or altering their contents without the written consent of Kashiyama is strictly prohibited.
- The company names and product names included in this operating manual are general trademarks or registered trademarks of their respective companies.
- The drawings of your pump may not be reflected in this operating manual. In addition, covers may be removed in some illustrations and photographs to more clearly explain the interior.
- Note that the contents in this operating manual are subject to change without a prior notice to users.
- This operating manual is written in English. If the Pump is handled by non-English-speakers, provide them with complete safety training. In addition, place the warning labels translated into their native languages.

Contact

Refer to the contact information at the end of this operating manual.

Definition of authorized personnel

This operating manual is prepared for all people involved with this Pump.

For safety reasons, Kashiyama classify authorized personnel as follows:

Only persons defined as authorized personnel are allowed to conduct the work specified in this operating manual. Authorized personnel may be asked to complete on-site training provided by Kashiyama.

Authorized personnel	Definitions
Administrator	<p>An administrator refers to a person responsible for maintenance and management of the Pump, safety management of operators and actions taken to prevent emergency situations (fire, etc.) and minimize damage.</p> <p>The Administrator provides operators with regular training regarding all relevant laws, regulations and safety matters.</p>
Operator	<p>An Operator refers to a person who has sufficient knowledge of the Pump and the necessary skills to operate it.</p> <p>They are required to have sufficient knowledge of Pump operation as a result of training provided by Kashiyama.</p>

Limited Warranty

In the event that the products (hereinafter referred to as the "Product(s) or Pump(s)") become faulty after delivery of the new Products and such fault is attributable to acts of Kashiyama, Kashiyama will warrant the fault by repairing or exchanging the Product at no cost to the user during the following warranty period determined by the purpose of use.

Provided however, this warranty clause shall apply only when the Product is used in the correct manner as described in this operating manual and/or other instruction manuals.

Period of Warranty by Usage

(Warranty period begins when newly purchased Products are delivered by Kashiyama)

2-year warranty: For exhausting clean gases (inert gas such as N₂ gas, dry air)

1-year warranty: For exhausting condensable gases (water vapor, solvent mixed gas)

(For solvent gas exhausting, to be consulted separately based on the type and volume of exhaustion)

- The abovementioned warranty is the sole and only warranty that Kashiyama offers in relation to the Pump.
This operating manual does not create any new contract, agreement or warranty. Kashiyama shall not, before or after the expiration date and/or regardless of causes and reasons, be liable for any compensation for damage and losses suffered by the users, including direct and indirect losses, lost profits, operating losses and nonoperating losses, but not limited to aforementioned.
- Kashiyama shall provide a warranty only to the original purchasers of the Pump. Third parties that have purchased and use resold Pump are not covered by Kashiyama's warranty.

Matters not covered by this warranty

- Failures resulting from inappropriate handling, use or storage.
- Failures resulting from exhausting reactive gases and particular gases, including corrosion gas containing acid and alkaline.
- Failures resulting from the use of gases including a substantial amount of solid objects and condensable products.
- Failures resulting from not conducting required maintenance.
- Failures resulting from not following the instructions described herein in this operating manual or the use of maintenance/exchange parts other than those sold by Kashiyama.
- Failures resulting from the removal of pump enclosures and component parts.
- Failures resulting from repair or modification by a company other than Kashiyama or a company not authorized by Kashiyama.
- Any failure or damage deemed to be caused by operation or maintenance beyond the scope of specifications
- Any failure or damage resulting from natural disasters, including earthquakes, typhoons, floods, tsunamis and volcano eruptions, fire, wars, terrorists' activities and any other failure and damage resulting from abnormal operating conditions not attributable to Kashiyama.
- Any failure or damage resulting from environmental reasons of the location of the Pump, for example magnetic environmental stresses.
- Failures resulting from use of radiation.
- Any failure or damage other than those attributable to an act of Kashiyama.

This warranty clause shall not apply to consumable parts and service parts.

Contents

Important Notice Notice	i
Limited Warranty	iii
Contents	iv
1 For Safe Use of the Product	1
1.1 WARNINGS	1
1.1.1 Types and Meanings of Warning Descriptions	1
1.2 Dos and Don'ts	2
1.2.1 General Matters	2
1.2.2 Transfer, Connection and Installation	3
1.2.3 Miscellaneous	4
1.3 Types of Warning Labels and Their Locations	6
1.3.1 Types of Warning Labels	6
1.3.2 Label Location	6
1.4 Safety Protection Feature	7
1.5 Lockout/Tagout	7
1.5.1 Lockout	7
1.5.2 Tagout	7
1.6 Zero Energy State	8
1.7 Protection of Human Body	8
1.7.1 Personal Protective Equipment	9
1.8 Countermeasures for Emergencies	9
1.9 Dangerous and Poisonous Chemicals	10
1.9.1 Disposal of Waste Liquids, Solvents and Materials	10
1.9.2 Content of SDS	10
2 Unpacking and Checking Pump	11
2.1 Storage of Pump	11
3 Product Overview	12
3.1 Pump Main Unit	12
3.2 Electrical Parts	12
3.3 Multi-gas Ballast Mechanism (option)	13
3.4 Product Specifications	14
3.4.1 List of Specifications	14
3.4.2 Dimensions and Position of Gravity Center	15
3.5 Names of Each Part	19
3.5.1 NeoDry7G	19
3.5.2 NeoDry15G	21
3.5.3 NeoDry30G	23
3.5.4 NeoDry36G	25
3.6 Exhaust Performance Curve	27
4 Pump installation	29
4.1 Installation	29
4.2 Installation Conditions	30
4.2.1 NeoDry7GPump Fixing Location	32

4.2.2	NeoDry15G Pump Fixing Location	33
4.2.3	NeoDry30G Pump Fixing Location	34
4.2.4	NeoDry36G Pump Fixing Location	35
4.3	Pipes	36
4.3.1	Vacuum and Exhaust Pipes.....	36
4.4	Electrical Wiring	37
4.4.1	Power Cabling (Connector code: CN1 (power connector)).....	37
4.4.2	Wiring for Control Power (Connector code: CN2 (I/O connector))	38
4.4.3	Wiring for Serial Communication (Connector code: CN3 (serial communication connector))	40
4.4.4	Wiring for Valve Controlling (Connector code: CN-SV (valve control connector))	41
5	Operating Panel	43
5.1	Operating Panel	43
5.2	LED Display	44
5.2.1	List of Group Code.....	44
5.2.2	Operational Procedures	45
5.2.3	List of Contents of LED Display.....	46
6	Operation and Stop	49
6.1	Operation Preparation	49
6.2	Operation and Stop.....	49
6.2.1	Operation Using Operating Connectors (direct-on-line operation)	51
6.2.2	Operation Using an Operating Panel	53
6.2.3	Operation Using External Signals	54
6.2.4	Operation Using Serial Communication.....	55
6.3	Multi-gas Ballast Mechanism (option)	56
6.3.1	Type.....	56
6.3.2	Installation of the Multi-gas Ballast Mechanism	56
6.3.3	Multi-gas Ballast Valve Open/Close Procedures	59
6.3.4	Use.....	62
7	Maintenance and Inspection	64
7.1	Daily Inspection	64
7.2	Intake/Exhaust Port Pipes	65
7.3	Lubricant	65
7.4	Overhaul	67
7.5	Pump Disassembling	68
7.6	Maintenance Standard.....	69
8	Troubleshooting.....	70
8.1	Basic Trouble	71
8.2	When Pump Errors Occur	72
9	After-sales Services	75
9.1	Supply of Service Parts for Repair	75
9.1.1	Period of Availability	75
9.1.2	Parts That Have Reached the End of the Period of Availability.....	75
9.2	When Requesting Repairs.....	75
9.3	Contact for Consultation	75

10 Disposal Procedures	75
10.1 Precautions for Disposal.....	75
11 Returning the Pump.....	76
11.1 Returning Procedures.....	76
Pump Return Form	77
Safety Data Sheet (lubricant).....	78
EC Declaration of Conformity.....	90
UK Declaration of Conformity.....	91

1 For Safe Use of the Product

This chapter describes the safety precautions necessary for handling the Pump.

1.1 Warnings

The following three methods are always available to alert users to risks and dangers.



- Warning messages in this operating manual
- Error indication (operating panel)
- Warning Label

Carefully read all of the warning messages in relation to safety precautions described in this instruction manual.

1.1.1 Types and Meanings of Warning Descriptions



■ Descriptions of indications

The "warning messages" in this operating manual provide warnings against possible risks and dangerous situations during operation together with "warning words" indicated by the following categories. If these warning messages are ignored, serious injury or accidents corresponding to the "warning word" could occur. In extreme cases, damage to the Pump or accessory devices, harm to the environment, as well as a fatal accident, could occur.

Types of warning words	Descriptions
 DANGER	This warning indicates a dangerous situation that, if ignored, will cause the risk of serious injury or a fatal accident of a user.
 WARNING	This warning indicates a dangerous situation that if ignored could cause the risk of serious injury of a user.
 CAUTION	This warning indicates a dangerous situation that if ignored could cause damage to the equipment or the risk of injury of a user.
<u>NOTICE</u>	This warning indicates information which needs to be emphasized or for which particular attention is necessary.

■ Graphic symbols and their meanings

The following two symbols are used to indicate cautions and display dangers.

Graphic Symbols	Descriptions
 (Prohibition)	This warning indicates the prohibition of dangerous actions.
 (General instruction)	This message indicates instructions relating to operation. In order to avoid risks, you will need to take these actions.

1.2 Dos and Don'ts

The points of observation and prohibited activities described herein (dos and don'ts) are guidelines to prevent death or bodily injury to users, property damage and environmental contamination.



If these dos and don'ts are not followed, it could cause serious injury to operators, damage to the Pump or cause environmental contamination. Be sure to understand all descriptions before operating the Pump.



1.2.1 General Matters

⚠ DANGER

	<p>Do not use the Pump to suction or exhaust inflammable gases or the gases harmful to the human body.</p> <p>* Otherwise, fire, bodily injury or a fatal accident could occur.</p>
---	---

⚠ WARNING

	<p>Do not touch it with wet hand.</p> <p>* Otherwise, an electric shock could occur.</p>
	<p>When conducting wiring and maintenance work, be sure to check that power is not supplied.</p> <p>* Otherwise, an electric shock could occur.</p>
	<p>The inlet port and vent pipes of the Pump could become hot. Pay attention not to allow them to contact combustible objects or a human body.</p> <p>* Otherwise, fire or bodily injury could occur.</p>
	<p>These parts are hot during operation and could stay hot for a while after the Pump has stopped.</p> <p>Conduct maintenance work after the Pump has sufficiently cooled down while paying attention not to allow it to contact combustible objects or a human body.</p> <p>* Otherwise, fire or burns could occur.</p>
	<p>Electric wiring shall only be conducted by qualified workers.</p> <p>* Otherwise, bodily injury and fire could occur.</p>
	<p>Be sure to ground the Pump.</p> <p>* Otherwise, an electric shock could occur.</p>
	<p>Be sure to conduct leak checks after the maintenance and inspection of pipes.</p> <p>Conduct leak checks by pressurizing the pipes. Apply a pressure of 0.05MPa from the exhaust pipe.</p> <p>* Otherwise, bodily injury could occur.</p>
	<p>Before maintenance and inspection, remove the disconnecting device.</p> <p>* Otherwise, an electric shock could occur</p>
	<p>Pump lifting can only be conducted by personnel qualified for machine operation, including forklifts and cranes. Pay attention to safety. (For NeoDry36G only)</p> <p>* Otherwise, bodily injury could occur.</p>



⚠ CAUTION	
	<p>Do not step on the Pump or place articles on it.</p> <p>* Otherwise, bodily injury resulting from rolling-over and failures of the Pump could occur.</p>
	<p>Do not disassemble the enclosure.</p> <p>* Otherwise, the Pump could fail or diminish in performance.</p>
	<p>Do not lift the Pump by putting a belt on the handle.</p> <p>When lifting the Pump, two operators shall hold the handle by hand. (NeoDry7G, 15G, 30G)</p> <p>* Otherwise, bodily injury and failures of the Pump could occur.</p>
	<p>Do not conduct withstand voltage tests.</p> <p>* Otherwise, instruments could fail or be deteriorated.</p>
	<p>For pipes and parts on both the inlet and exhaust side, use materials with sufficient resistance to corrosion for safe operation.</p> <p>* Otherwise, failures, Pump leaks, as well as bodily injury, could occur.</p>
	<p>Before supplying power, check that the inlet port and exhaust pipes are correctly connected.</p> <p>If power is supplied to the Pump while the pump ON signal is input, it will start to operate immediately.</p> <p>Take safety measures to prevent errors upon start of the Pump.</p> <p>* Otherwise, bodily injury and failures of the Pump could occur.</p>
	<p>When operation repeatedly starts and stops, operate the Pump by external signal changing or a serial communication.</p> <p>* Otherwise, the inverter life will become shorter and failures could occur.</p>
	<p>If an error has occurred while operating with an external signal, conduct maintenance and inspection after turning OFF the operation signal.</p> <p>* Otherwise, bodily injury and failures of the Pump could occur.</p>

1.2.2 Transfer, Connection and Installation

⚠ WARNING	
	<p>Do not enter the area below hoisted Pump.</p> <p>* Otherwise, bodily injury could be caused by a falling article.</p>

⚠ CAUTION	
	<p>Do not stack packaged Pumps or place them on their side.</p> <p>* Otherwise, failures of the Pump could occur.</p>
	<p>Do not place heavy articles directly on the inlet port or exhaust port.</p> <p>* Otherwise, leaks from a joint or failure of the Pump could occur.</p>
	<p>Do not install equipment that could be a heat source in front of the Pump.</p> <p>The ventilated gas temperature shall not be greater than the limit of Pump use.</p> <p>* Otherwise, failures of the Pump could occur.</p>

⚠ CAUTION

	<p>In the case of input signals (Pins No. 1-9, 2-10, 3-11, 4-12), DC24V is applied on the inverter side. Do not apply voltage from the user's equipment.</p> <p>* Otherwise, failures of the controller could occur.</p>
	<p>Do not connect valves that exceed the power source capacity.</p> <p>* Otherwise, failures of the Pump and electrical devices could occur.</p>
	<p>Do not short-circuit the output of valve control connectors.</p> <p>* Otherwise, failures of the Pump and electrical devices could occur.</p>
	<p>Do not feed N2 gas, with the maximum feeding pressure of 0.05MPa or greater, to the multi-gas ballast mechanism.</p> <p>* Otherwise, failures of the Pump could occur.</p>
	<p>When condensable gases, including water vapor, is exhausted, do not stop the Pump immediately after exhausting.</p> <p>Before stopping, continue Pump operation for about one hour with the inlet port open.</p> <p>* Otherwise, condensed moisture remaining inside the Pump could cause failures such as corrosion.</p>
	<p>When installing the Pump, for cooling purposes maintain space for ventilation; 100 mm or greater in the front and back, and 50 mm or greater on either side.</p> <p>* Otherwise, failures of the Pump could occur.</p>
	<p>Remove the attached grommet when wiring to the valve control connector.</p> <p>Be sure to install the grommet when the valve control connector is not wired.</p> <p>* Otherwise, failures of the Pump could occur.</p>



1.2.3 Miscellaneous

■ Storage

⚠ CAUTION

	<p>Store the Pump where the inside will remain dry.</p> <p>* Leaving the Pump with the condensable gases, such as water vapor, remaining inside the Pump could cause rotation problems during subsequent startup.</p>
---	---



■ Multi-gas ballast mechanism (option)

⚠ CAUTION	
	<p>Do not install to the ballast gas inlet part anything other than the optional multi-gas ballast mechanism.</p> <p>* Otherwise, failures of the Pump could occur.</p>
	<p>When exhausting condensable gas, be sure to use the multi-gas ballast mechanism (option) to take in the ballast gas for operation.</p> <p>* Otherwise, failures of the Pump could occur.</p>
	<p>When using the multi-gas ballast mechanism to exhaust condensable gas, use the Pump after warming it up sufficiently (after an hour of warming or longer).</p> <p>When the Pump is cold, its “multi-gas ballast treatment capability” will not be fully functional.</p> <p>* Condensation of condensable gases in the Pump room could lead to failures.</p>
	<p>Do not allow condensation within the exhaust side pipe to flow back into the Pump. Condensable gases that do not condense within the Pump could condense within the exhaust side pipe.</p> <p>* Otherwise, failures of the Pump could occur.</p>
	<p>Be sure to install the Pump in a dust-free environment.</p> <p>The air intake multi-gas ballast type is provided with a filter to avoid foreign materials included in the air do not enter into the Pump while taking air in. If the Pump operates in a dusty environment, foreign materials in the air will adhere to the filter, reducing the flowrate of ballast gas being fed.</p> <p>* Condensation of condensable gases within the Pump could no longer occur, leading to Pump failures.</p>

1.3 Types of Warning Labels and Their Locations

1.3.1 Types of Warning Labels

The following caution labels are placed on the main body of the Pump to call for attention during use.

No.	[1]	[2]	[3]
Contents of warning labels	Risk of electric shock	Risks of fire	Refer to the attached documents
Warning Label			

1.3.2 Label Location

Warning labels are attached at the locations indicated in the illustration.

NeoDry7G

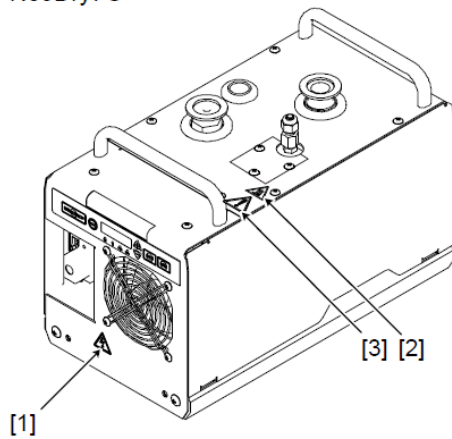

NeoDry15G

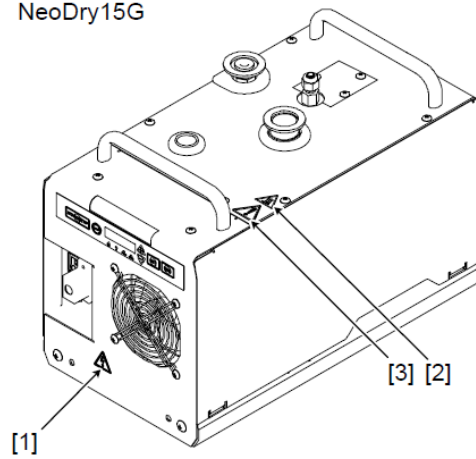

NeoDry30G

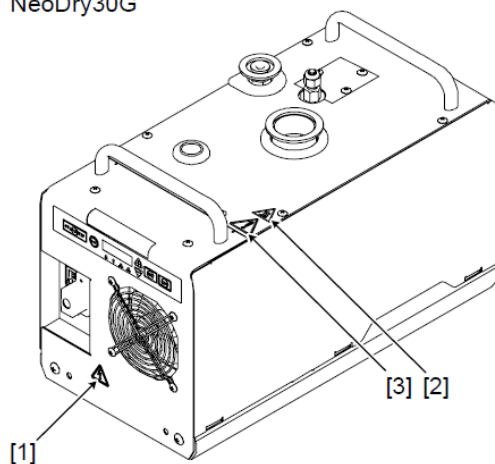

NeoDry36G

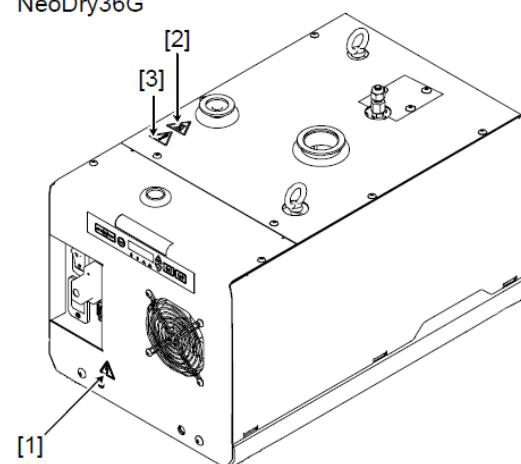

KA00001

Fig. 1.1 Warning labels and their locations

1.4 Safety Protection Feature

When a Pump error occurs, a message will be displayed on the LED indicator panel [1]. Follow the necessary procedures according to the content of the message.

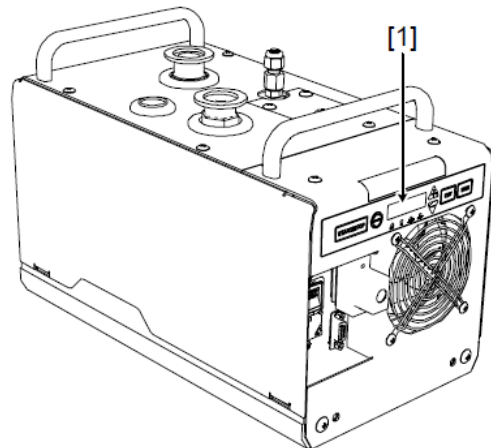

* This illustrates NeoDry7G.
KA00064

Fig. 1.2 Safety protection feature

1.5 Lockout/Tagout

1.5.1 Lockout

Lockout is a procedure to secure the safety of operators during maintenance and inspection activities, such as when exchanging parts.

- Lock the power sources with padlocks [1] so that no person, other than the operators, will be able to turn power ON.
- One operator holds the padlock key [1] so that other operators will not be able to operate the Pump.

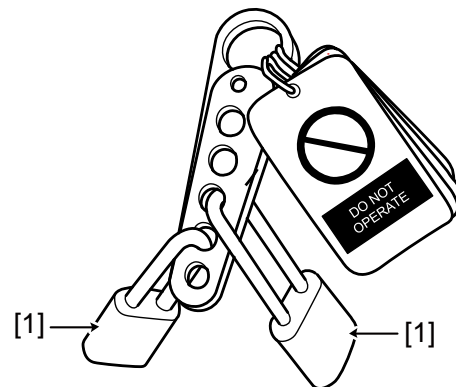

KA00039

Fig. 1.3 Lockout

1.5.2 Tagout

Tagout is a procedure to attach tags with warning messages, prohibiting to unlock the lock by taking any procedures other than pre-determined. Write the name of the supervisor responsible for the operation or the name of the worker who attached the tag.

- The following illustrations are samples of tags. Check that tags suitable for each operating environment are attached.

Tagout shall be reset by the supervisor responsible for the operation or by the operator who attached the tag.

It is prohibited for any other operator to reset the tagout.



KA00040

Fig. 1.4 Tagout

1.6 Zero Energy State

A "zero energy state" means that a state is maintained to prevent the unintended release or input of energy during activities such as maintenance. In other words, when the energy is not in use, unintended energy is neither released nor supplied in this state even if the actual energy is not zero.

- 1 Turn OFF the main switch [1].
- 2 Stop power supply to the Pump.
 - The Pump stops and the status bar [2] changes color from green to white and then turns OFF.
- 3 If the inside of the Pump is in a vacuum state, release the pressure.
 - When releasing the pressure, open the inlet port to the atmosphere.

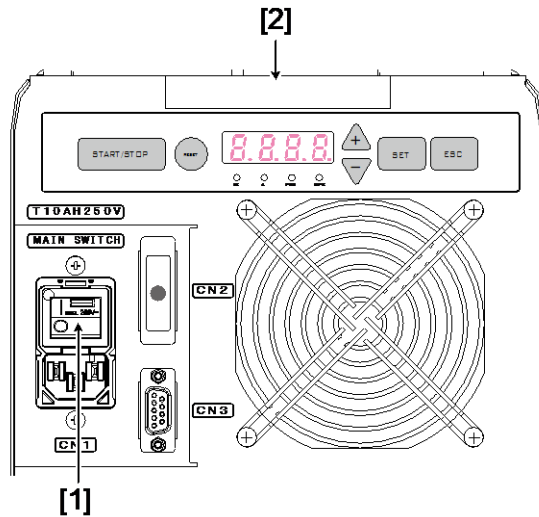

KA00060A

1.7 Protection of Human Body

To use this Pump, observe the following requirements for protection of human body.



KA00065

Fig. 1.5 Safety protection

1.7.1 Personal Protective Equipment

Personal protective equipment differs according to working environment and operation contents (operation, maintenance and inspection, etc.).

Establish rules and wear the required personal protective equipment.

<Basic Personal Protective Equipment to be Worn>

- Uniform
- Steel-toe work shoes
- Hard hat (helmet)
- Protective gloves
- Eye protector (protective glasses)

Work in outfits suitable for safety.

Wear a uniform that fits the body. Cuffs of sleeves must be fastened.

Correct clothing is useful for preventing electric shock.

Wearing short-sleeved operation or short pants could cause injury when coming in contact with some objects.

1.8 Countermeasures for Emergencies

It is important to develop procedures for emergency and rescue operators who are involved in accidents.

Determine the emergency procedures for injury, property damage and environmental disasters so that immediate actions for emergencies can be taken.

1.9 Dangerous and Poisonous Chemicals

Being exposed to chemicals could cause serious health problems, such as heart disease, damage to kidneys and lungs, infertility, cancer, burn injury or rash. Some chemical substances have the risk of causing a fire, explosion or other serious accidents when mishandled.

When purchasing such dangerous and poisonous chemicals, obtain SDSs (Safety Data Sheet) from manufacturers and keep them in a place where they can be easily accessed when the chemicals are used.

When seeing a doctor for treatment after using dangerous and harmful chemical substances, provide the doctor with an SDS.

Those who handle these dangerous and poisonous chemicals need to be informed about the information of the chemicals and receive education and training in accordance with the provisions of JIS Z 7253 (2012) and ISO 11014 (1994).

1.9.1 Disposal of Waste Liquids, Solvents and Materials

Chemicals such as solvents used and waste cloths stained with such chemicals are subject to various regulations for environmental protection when they are disposed.

It is required that these chemicals are controlled in accordance with the nation's or local government's regulations and the user's own regulations. Companies with ISO14001 certification must comply with their own procedures.

1.9.2 Content of SDS

The detailed information about dangerous points related to health and safety, including impact on the environment, safe handling and countermeasures in case of emergency are included in SDS.

2 Unpacking and Checking Pump

Pumps are securely inspected and packed before being shipped. Upon receipt of the Pump, unpack it and check the following points.

- Are all component parts available?
- Is the Pump exactly in accordance with the specifications as ordered?
- Has any damage occurred to the Pump during transportation?

Contact the contact information at the end of this operating manual for any defectives. Confirm the accessory parts by referring to the attached "Shipping Statement."

2.1 Storage of Pump

If the Pump is not installed immediately after delivery, store it under the following conditions.

CAUTION



Do not stack packaged Pumps or place them on their side.

* Otherwise, failures of the Pump could occur.

- Indoor
- Environmental contamination level 2 (where there is little dust)
- Temperature: 5 to 40°C
- Humidity: 80% or lower (Dew condensation not allowed)
- Altitude: 2,000 m or lower

3 Product Overview

The Pump consists of the main unit and electrical parts fixed on the base and covered by an enclosure.

3.1 Pump Main Unit

- A pair of right and left rotors are synchronously rotated while maintaining very small clearance. These are used to transfer gas from the inlet port to the exhaust port.
- A gear is installed to one of the two rotors and this is lubricated with lubricant.
- A synchronous motor is used.
- The Pump becomes extremely hot due to gas compression heat and frictional heat of the bearings and seals, therefore a cooling fan is used to lower the temperature.
- To exhaust condensable gases, use the multi-gas ballast mechanism (option) to prevent the inside Pump to condensed.

3.2 Electrical Parts

The built-in parts differ according to the Pump type.

■ NeoDry7G · 15G · 30G

A power entry module (with switches, fuses and noise filters) and an inverter are built into the enclosure.

■ NeoDry36G

The noise filter, circuit protector and inverter are enclosed in the enclosure.

3.3 Multi-gas Ballast Mechanism (option)

When exhausting condensable gases (a mixture of water vapor and solvent), the gas will condense (liquidize) within the Pump if the mixed gas components exceed the saturated vapor pressure. The multi-gas ballast mechanism prevents such condensation by supplying external air or N₂ gas (ballast gas) to the Pump and lowering the partial pressure of the condensable gases being vacuumed from the inlet port. The intake of ballast gas will lead to the exhausting of condensable gases from the exhaust port before they can condense within the Pump.

3.4 Product Specifications

3.4.1 List of Specifications

Items		Model			
		NeoDry7G	NeoDry15G	NeoDry30G	NeoDry36G
Maximum exhausting speed		110 L/min	250 L/min	500 L/min	600 L/min
Achieved pressure (*1)	When multi-gas ballast valve is closed	5.0 Pa	1.0 Pa		0.7 Pa
	When multi-gas ballast valve is open	35 Pa	10 Pa		
Multi-gas ballast N2 feeding model N2 feed pressure (gauge reading) (*2) [Set pressure of regulator]		0.01 to 0.05 MPa			
Max. inlet port pressure		Atmospheric pressure			
Max. exhaust back pressure (gauge reading)		3 kPa or less			
Motor used		0.4 kW			0.75 kW
Rated current [50/60 Hz]		5.0 A	7.5 A		11 A
Operating current [50/60 Hz] (Primary side current) (*3)		0.9 to 5.0 A	1.3 to 7.5 A	1.4 to 7.5 A	2.0 to 11 A
Inlet port diameter		NW25 (quick flange)		NW40 (quick flange)	
Exhaust port diameter		NW25 (quick flange)			
Lubricant	Product name	Fluorine oil: FOMBLIN® Y LVAC 25/6E			
	Amount of oil	0.02 L	0.12 L		0.24 L
Estimated weight		19 kg	22 kg	24 kg	51 kg
Outer dimensions: W x L x H		196 x 360 x 196 mm	210 x 385 x 219 mm	210 x 410 x 219 mm	298 x 475 x 315 mm
Operating environment	Temperature	5 to 40°C	10 to 40°C		
	Humidity	20 to 80% (dew condensation not allowed)			
Degree of environmental pollution at the place of installation		Contamination level 2			
Over-voltage category		Category II			
Altitude		2,000m or lower			
Power source	Voltage [50/60 Hz]	100-240 V			
	Voltage fluctuation tolerance (*4)	±10%			
	Capacity	0.5 kVA	0.8 kVA		1.1 kVA
Adaptable safety standard (*5)		NRTL (UL61010-1, CAN/CSA C22.2 No.61010-1) CE Marking UKCA KC			

*1 The multi-gas ballast mechanism is an optional feature.

*2 The N2 feed pressure when the multi-gas ballast N2 feeding model is used.

*3 Depending on the power supply equipment used, this value may not be within the range.

*4 This is the voltage fluctuation tolerance, not the stationary voltage tolerance.

*5 For details on overseas safety standards, refer to the contact information at the end of this operating manual.

3.4.2 Dimensions and Position of Gravity Center

- NeoDry7G (without casters or adjusters).

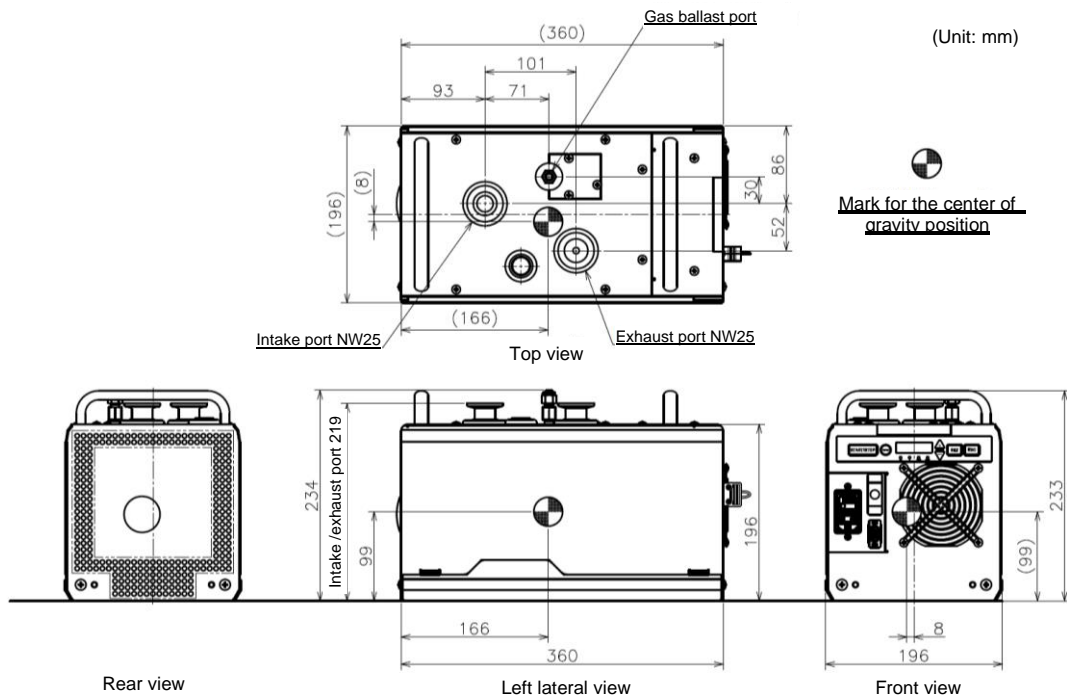

Fig. 3.1

- NeoDry7G (with casters and adjusters) (option)

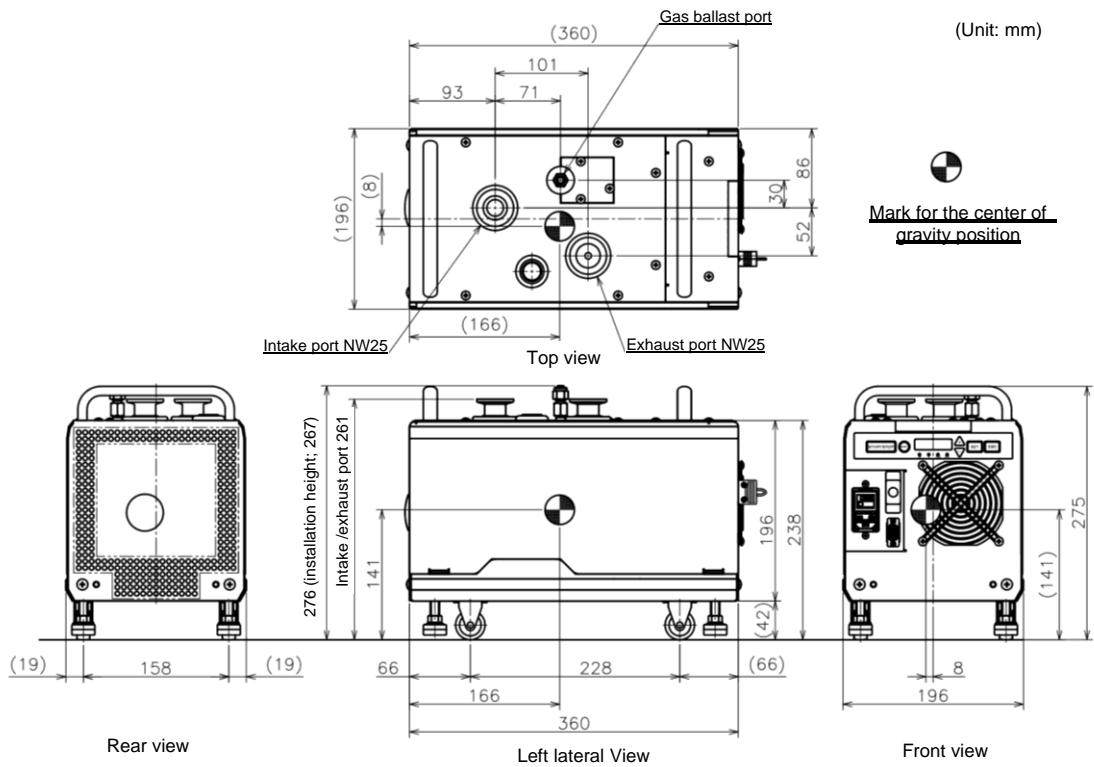

Fig. 3.2

■ NeoDry15G (without casters or adjusters).

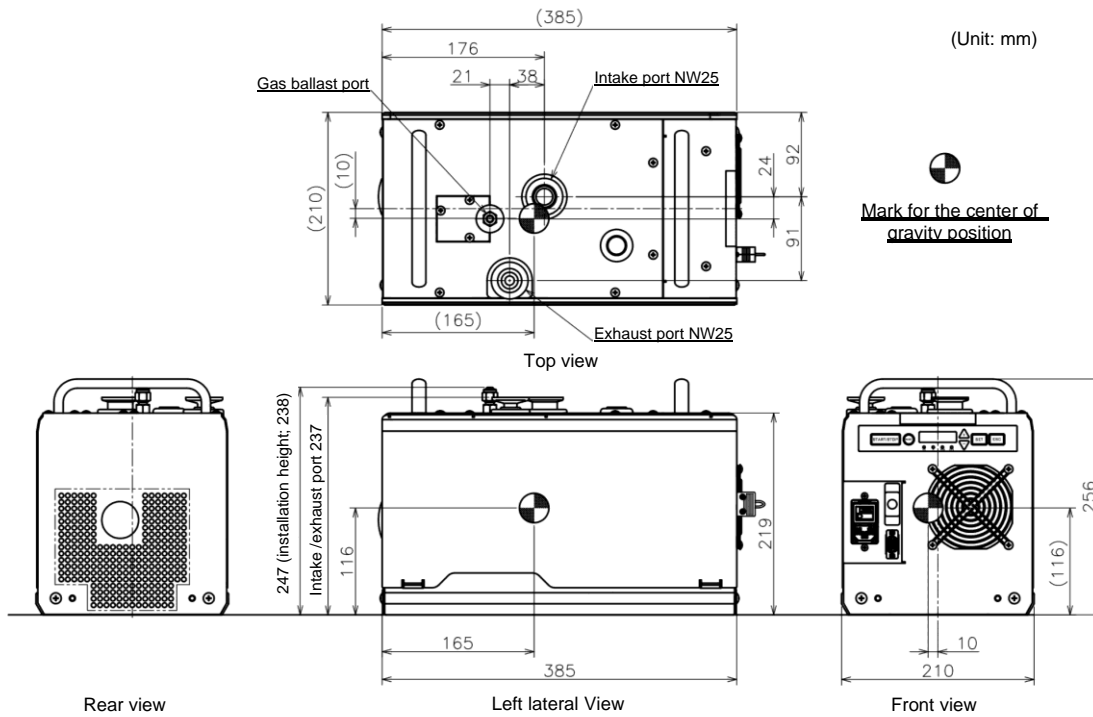

Fig. 3.3

■ NeoDry15G (with casters and adjusters) (option)

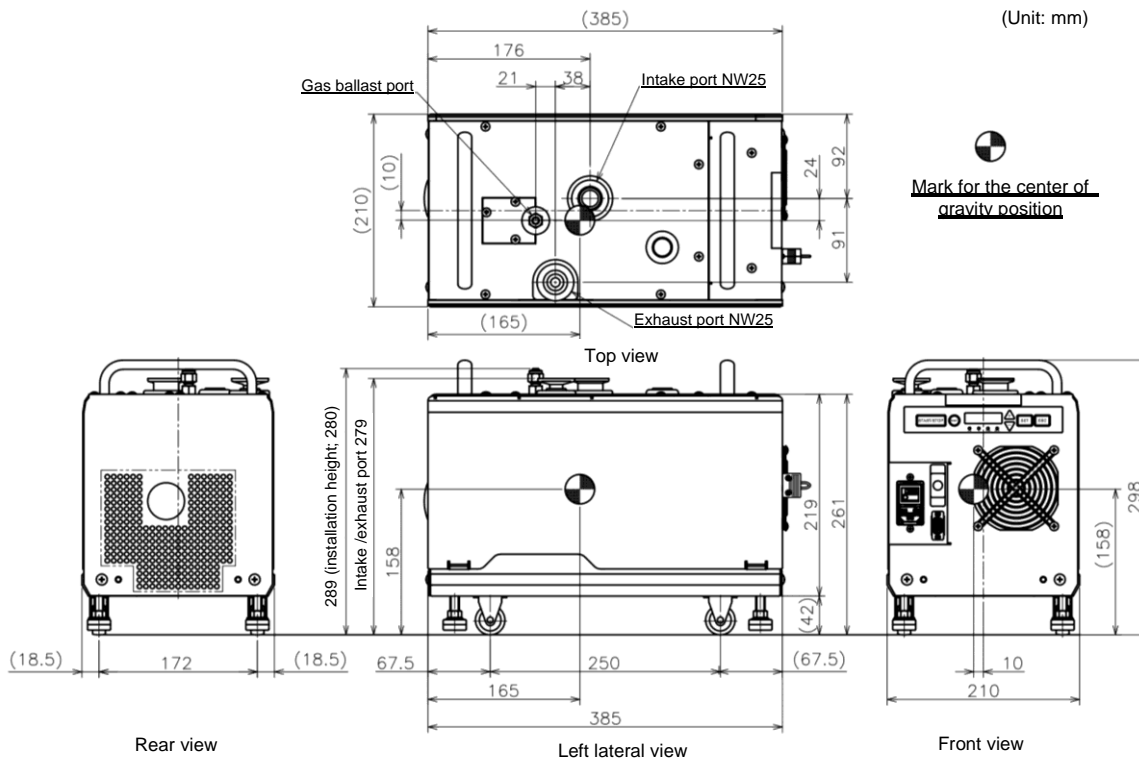

Fig. 3.4

■ NeoDry30G (without casters or adjusters).

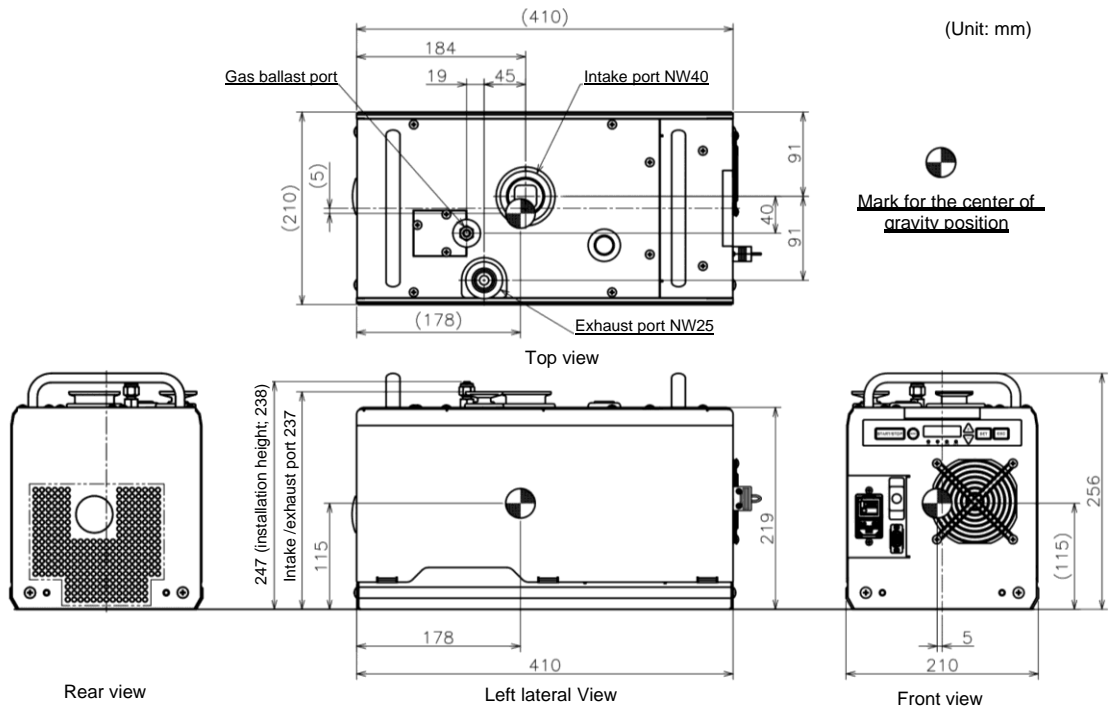

Fig. 3.5

■ NeoDry30G (with casters and adjusters) (option)

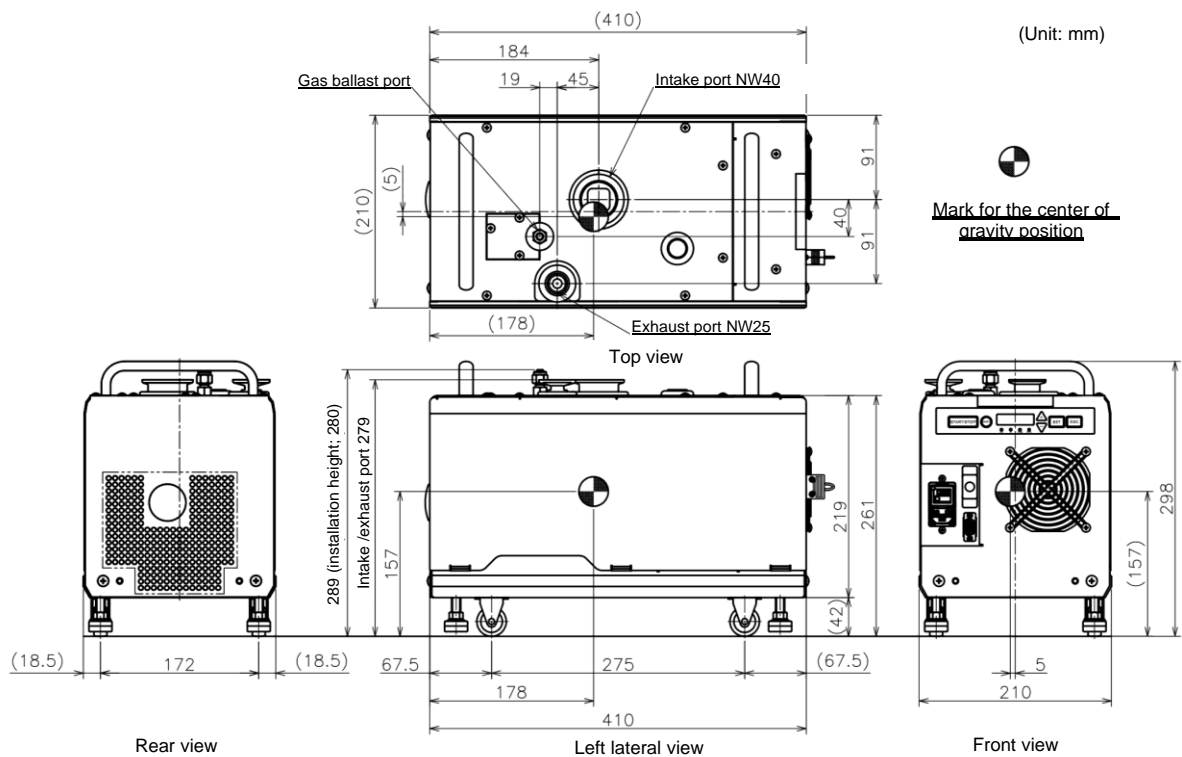

Fig. 3.6

■ NeoDry36G (without casters or adjusters).

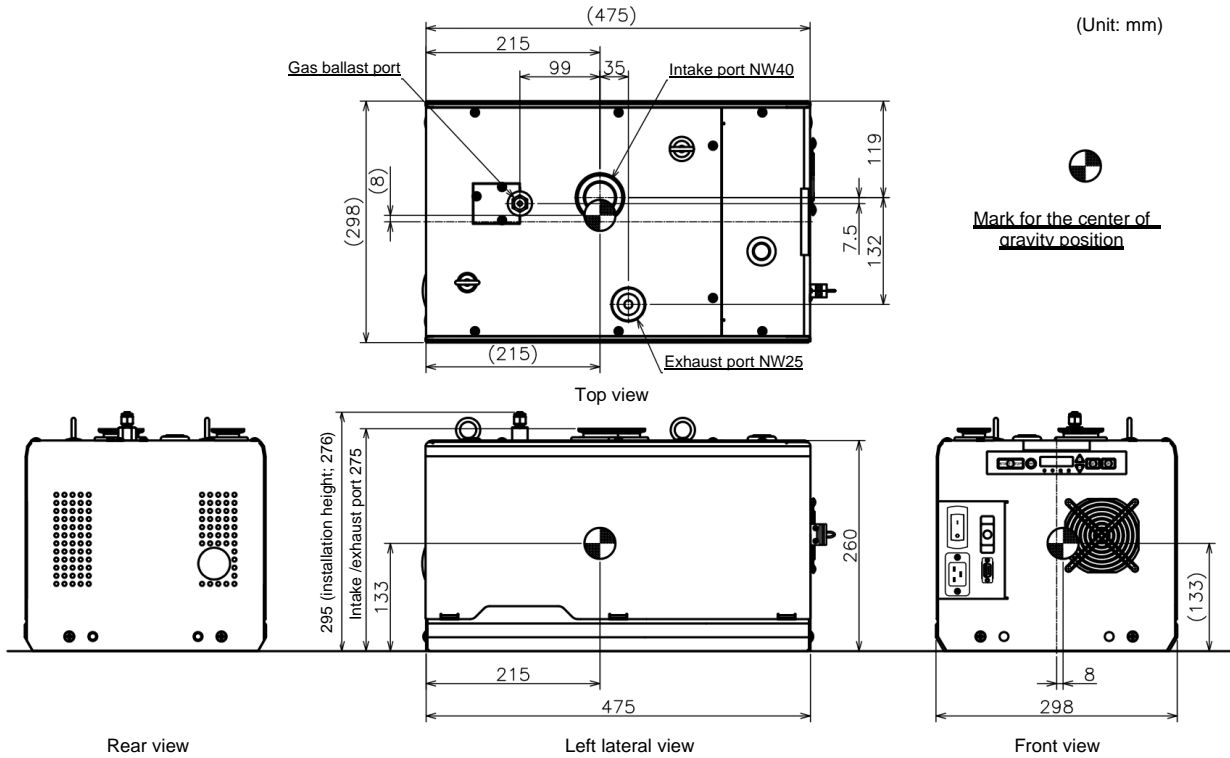

Fig. 3.7

■ NeoDry36G (with casters and adjusters) (option)

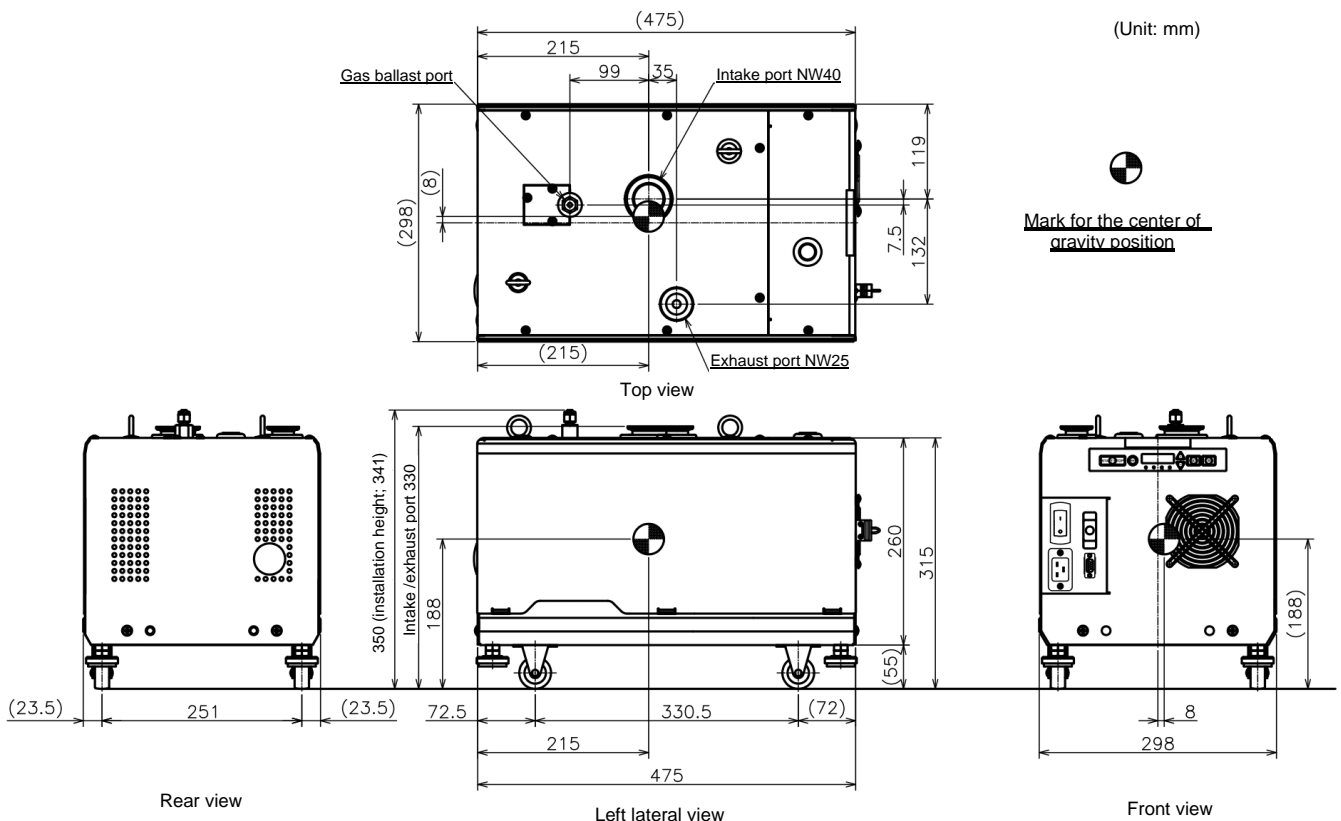

Fig. 3.8

3.5 Names of Each Part

3.5.1 NeoDry7G

- Without casters or adjusters

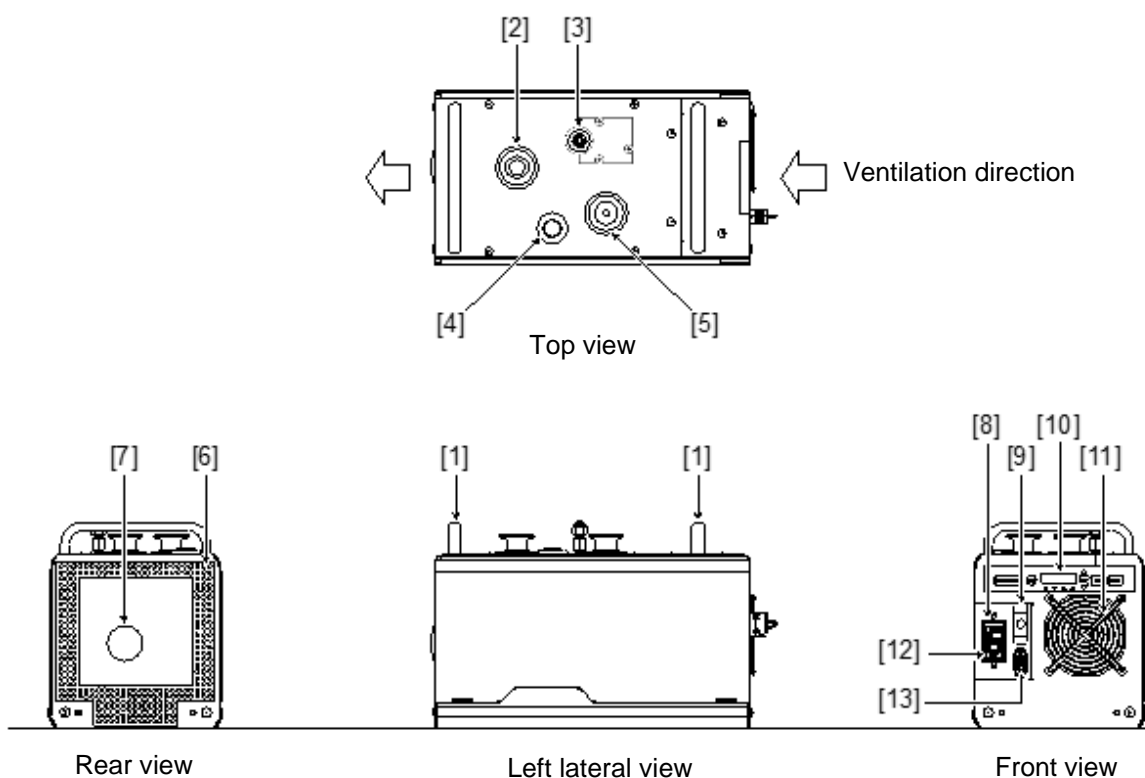
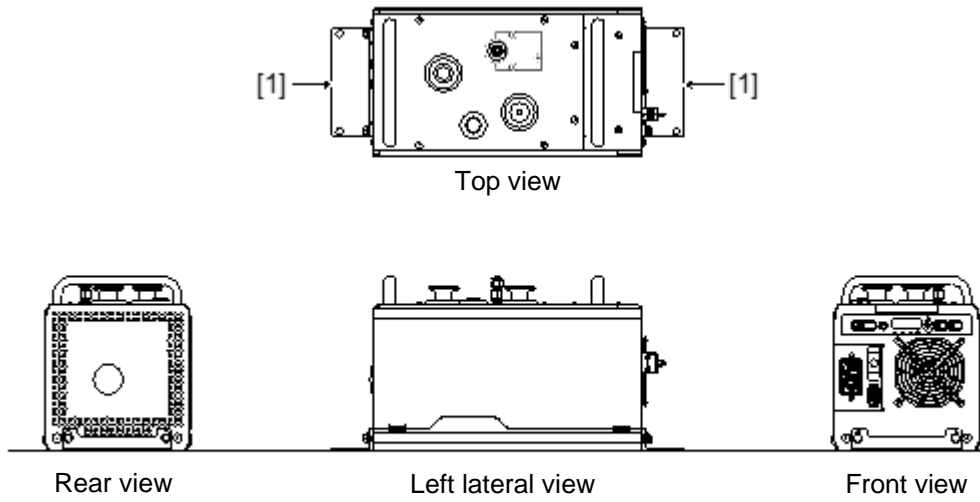

Fig. 3.9

No.	Name	No.	Name
[1]	Handle	[8]	Main switch
[2]	Intake port NW25	[9]	Remote control connector CN2
[3]	Multi-gas ballast port	[10]	Operating panel (hour meter display)
[4]	Valve control connector CN- SV	[11]	Cooling air suction port
[5]	Exhaust port NW25	[12]	Power connector CN1
[6]	Cooling air discharge port	[13]	External communication connector CN3
[7]	Blank plug (for checking oil level)	—	—

■ With a pump bracket (option)



KA00011A

Fig. 3.10

No.	Name	No.	Name
[1]	Pump bracket (option)	—	—

■ With a pump bracket, adjusters and casters (option)

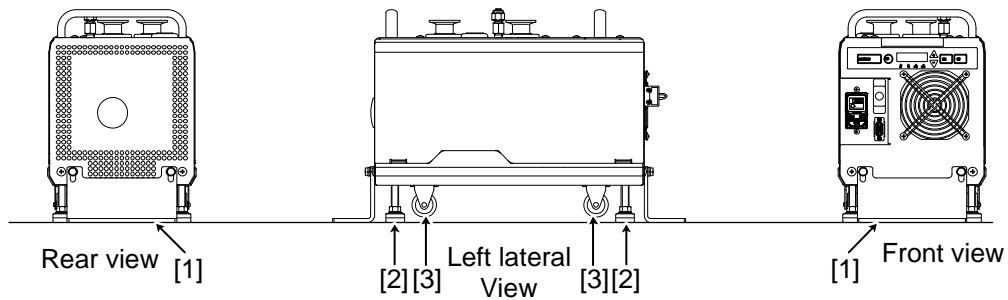

KA00012A

Fig. 3.11

No.	Name	No.	Name
[1]	Pump bracket (option)	[3]	Caster
[2]	Adjuster	—	—

3.5.2 NeoDry15G

- Without casters or adjusters

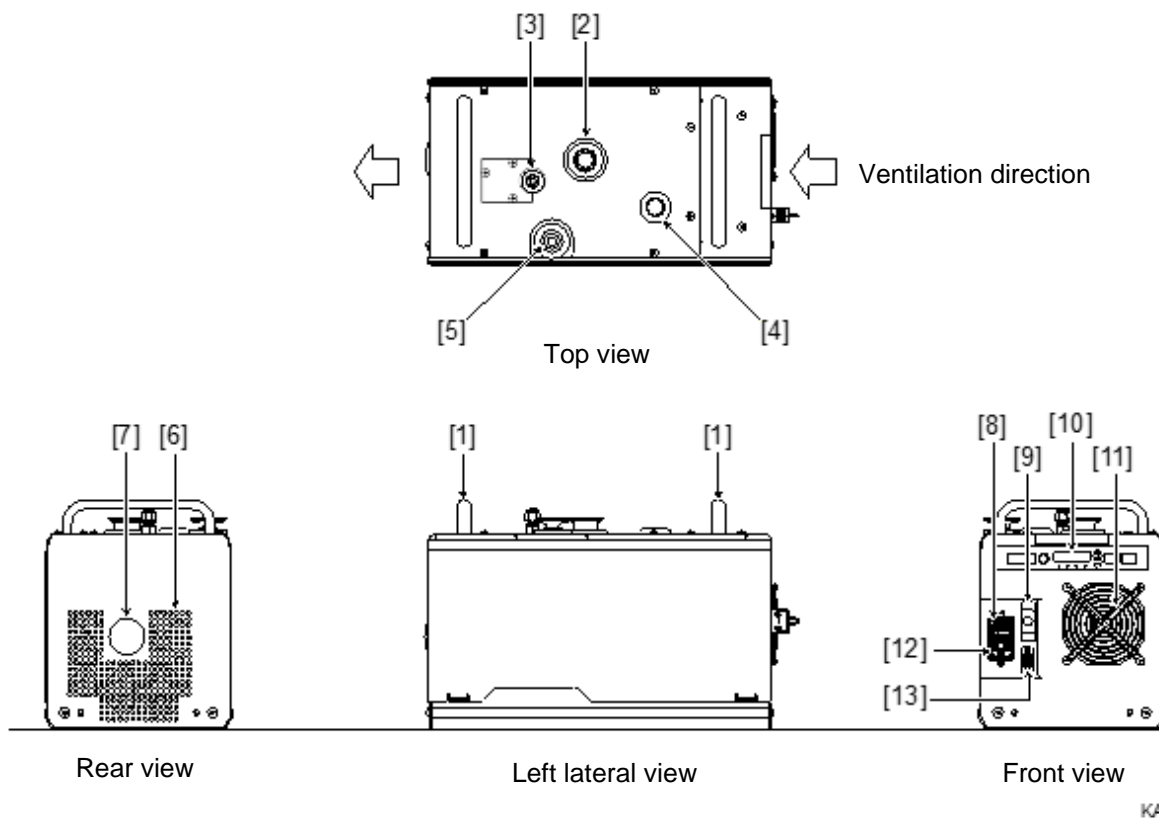
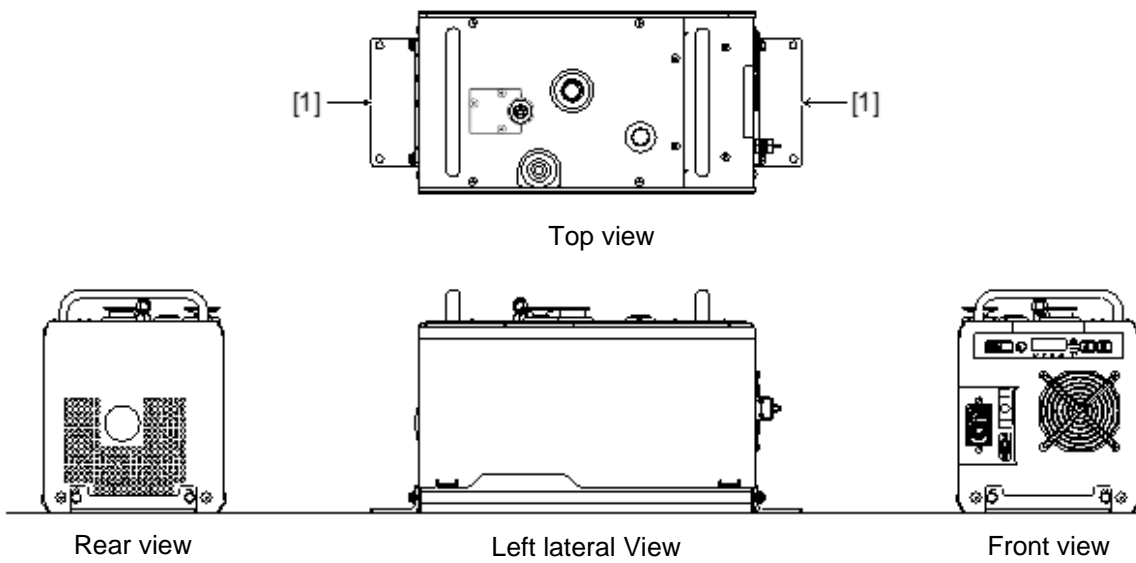

Fig. 3.12

No.	Name	No.	Name
[1]	Handle	[8]	Main switch
[2]	Intake port NW25	[9]	Remote control connector CN2
[3]	Multi-gas ballast port	[10]	Operating panel (hour meter display)
[4]	Valve control connector CN- SV	[11]	Cooling air suction port
[5]	Exhaust port NW25	[12]	Power connector CN1
[6]	Cooling air discharge port	[13]	External communication connector CN3
[7]	Blank plug (for checking oil level)	—	—

■ With a pump bracket (option)



KA00014A

Fig. 3.13

No.	Name	No.	Name
[1]	Pump bracket (option)	—	—

■ With a pump bracket, adjusters and casters (option)

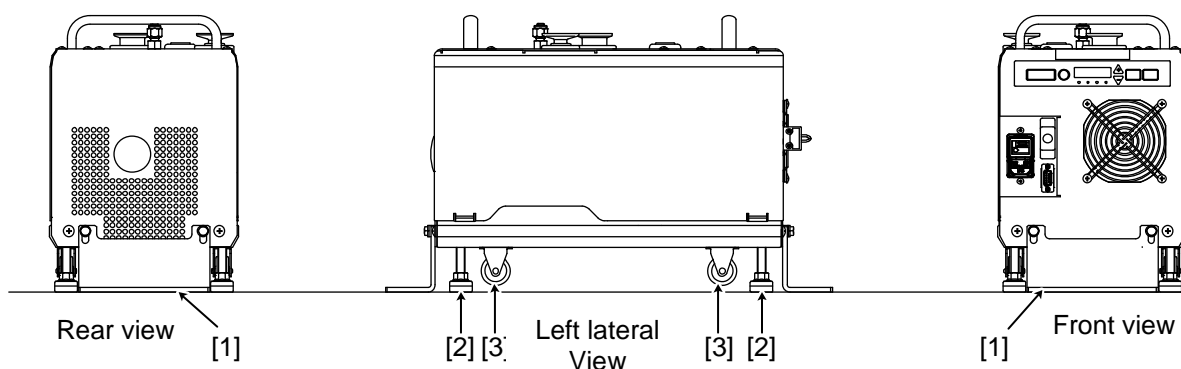

KA00015A

Fig. 3.14

No.	Name	No.	Name
[1]	Pump bracket (option)	[3]	Caster
[2]	Adjuster	—	—

3.5.3 NeoDry30G

- Without casters or adjusters

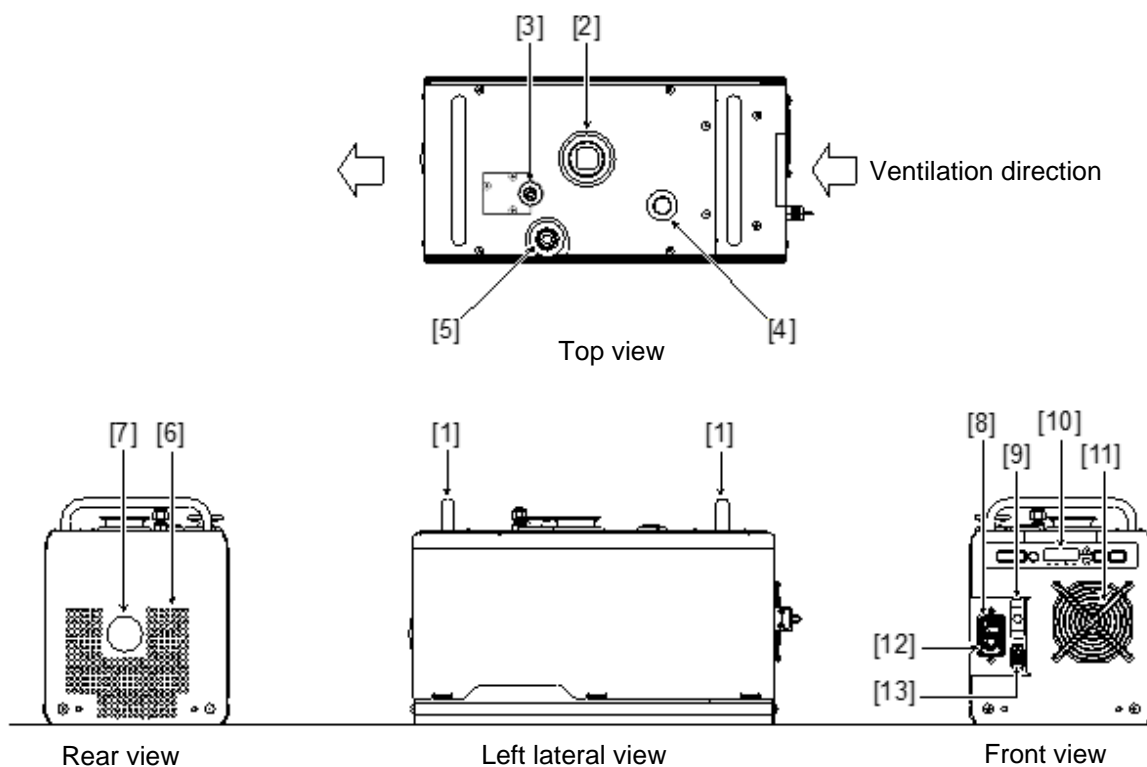

KA00016A

Fig. 3.15

No.	Name	No.	Name
[1]	Handle	[8]	Main switch
[2]	Intake port NW40	[9]	Remote control connector CN2
[3]	Multi-gas ballast port	[10]	Operating panel (hour meter display)
[4]	Valve control connector CN- SV	[11]	Cooling air suction port
[5]	Exhaust port NW25	[12]	Power connector CN1
[6]	Cooling air discharge port	[13]	External communication connector CN3
[7]	Blank plug (for checking oil level)	—	—

■ With a pump bracket (option)

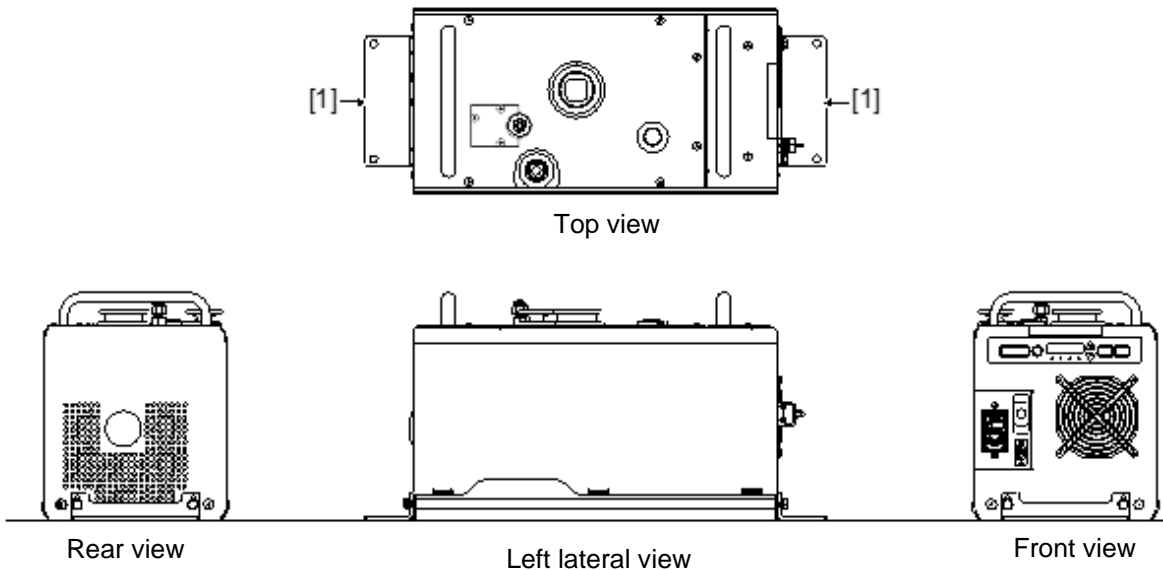

KA00017A

Fig. 3.16

No.	Name	No.	Name
[1]	Pump bracket (option)	—	—

■ With a pump bracket, adjusters and casters (option)

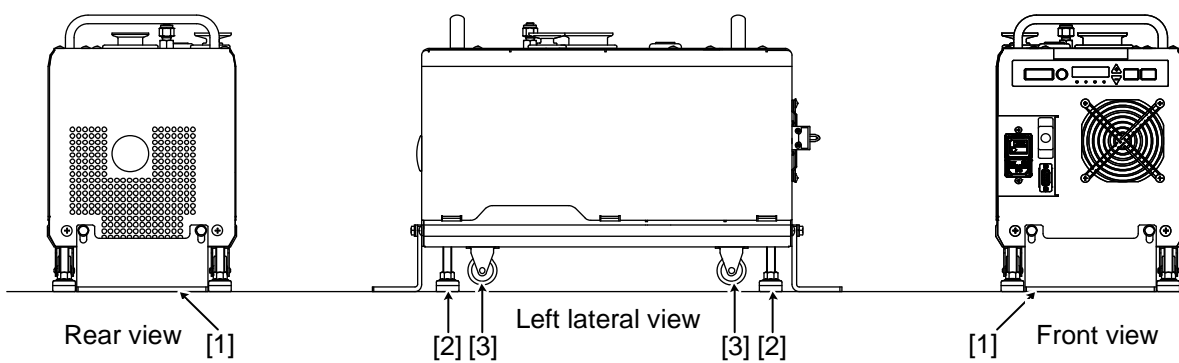

KA00018A

Fig. 3.17

No.	Name	No.	Name
[1]	Pump bracket (option)	[3]	Caster
[2]	Adjuster	—	—

3.5.4 NeoDry36G

- Without casters or adjusters

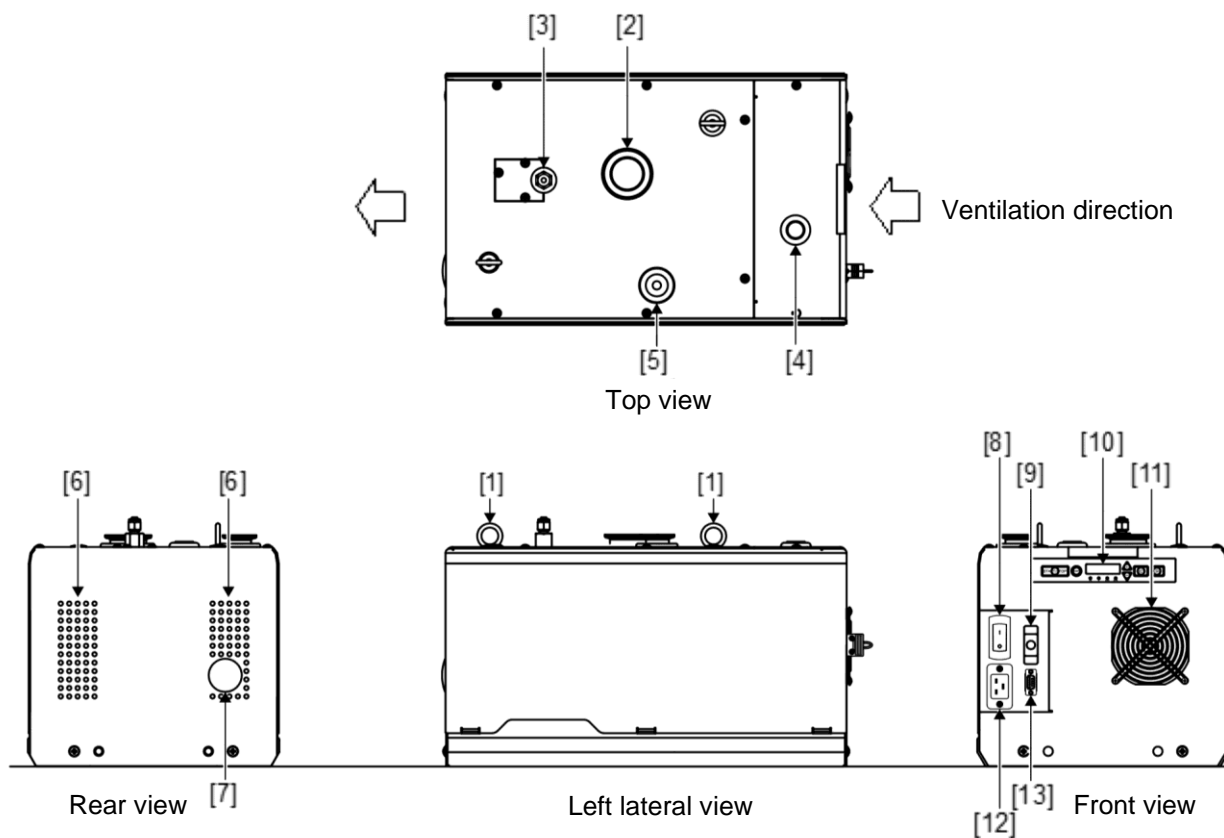

Fig. 3.18

No.	Name	No.	Name
[1]	Eyebolt M8	[9]	Remote control connector CN2
[2]	Intake port NW40	[10]	Operating panel (hour meter display)
[3]	Multi-gas ballast port	[11]	Cooling air suction port
[4]	Valve control connector CN- SV	[12]	Power connector CN1
[5]	Exhaust port NW25	[13]	External communication connector CN3
[6]	Cooling air discharge port	—	—
[7]	Blank plug (for checking oil level)	—	—
[8]	Main switch	—	—

■ With a pump bracket (option)

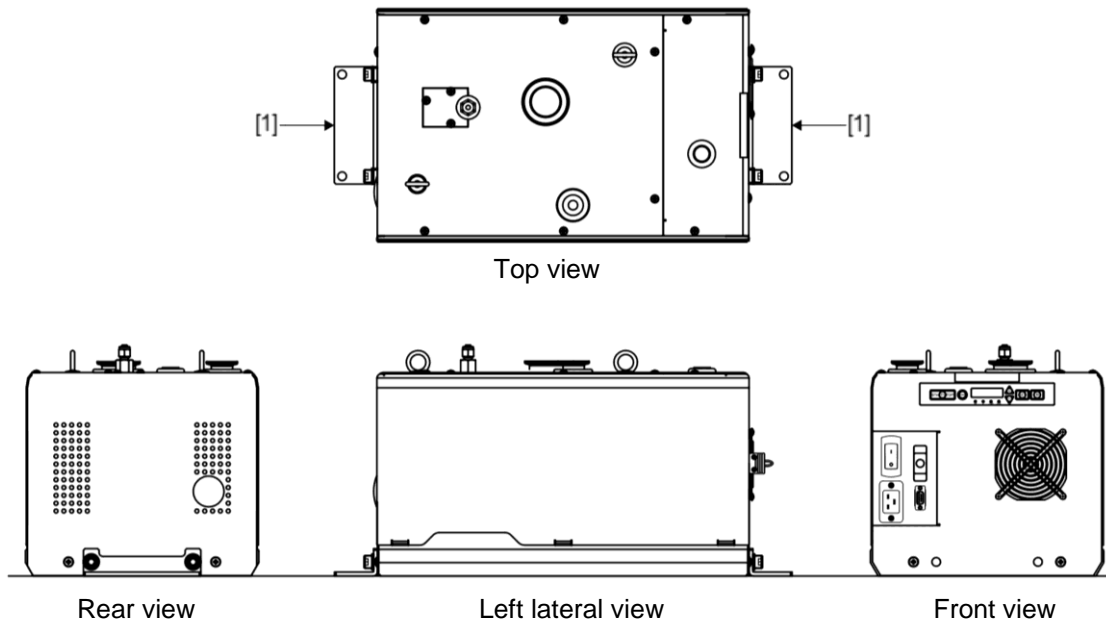

Fig. 3.19

No.	Name	No.	Name
[1]	Pump bracket (option)	—	—

■ With a pump bracket, adjusters and casters (option)

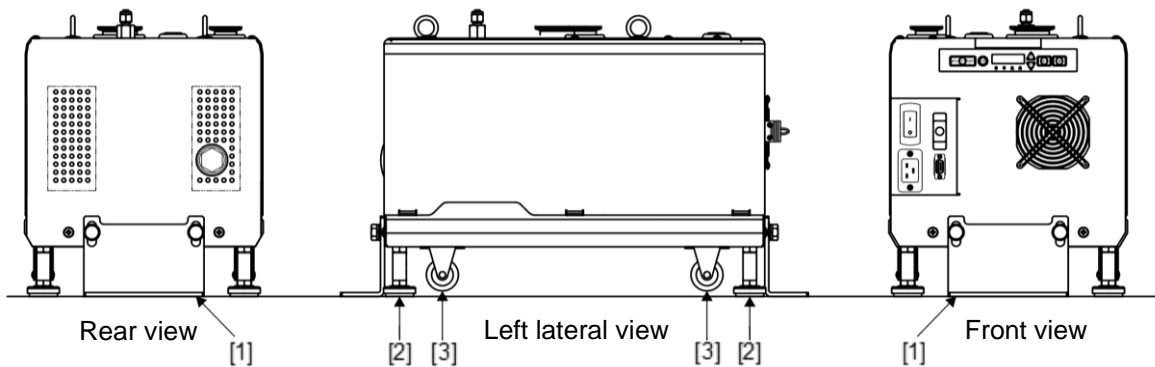

Fig. 3.20

No.	Name	No.	Name
[1]	Pump bracket (option)	[3]	Caster
[2]	Adjuster	—	—

3.6 Exhaust Performance Curve

■ NeoDry7G

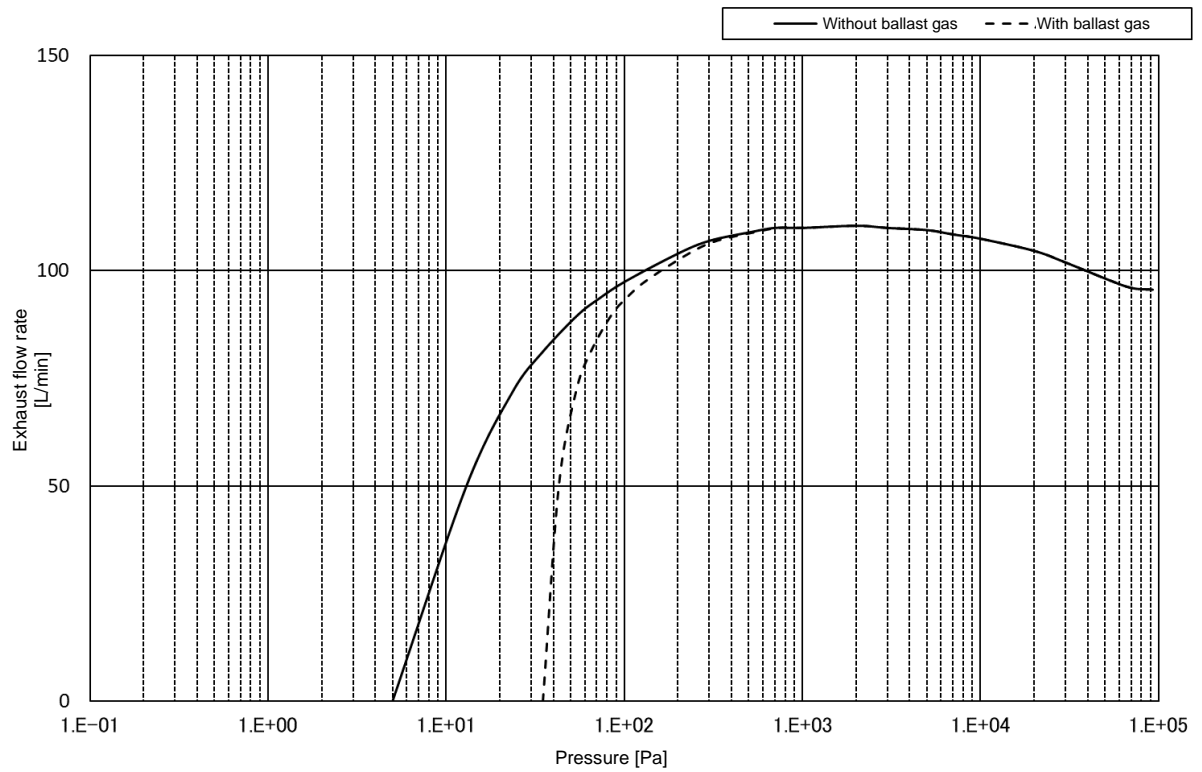

Fig. 3.21

■ NeoDry15G

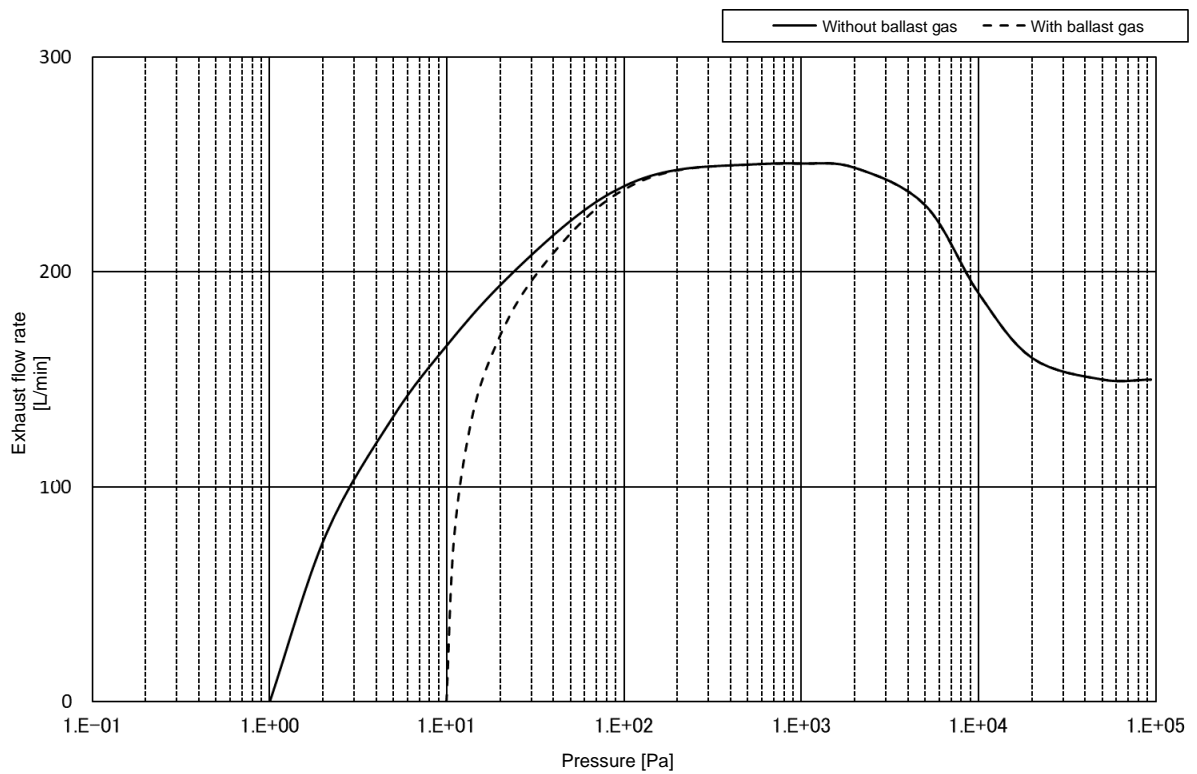

Fig. 3.22

■ NeoDry30G

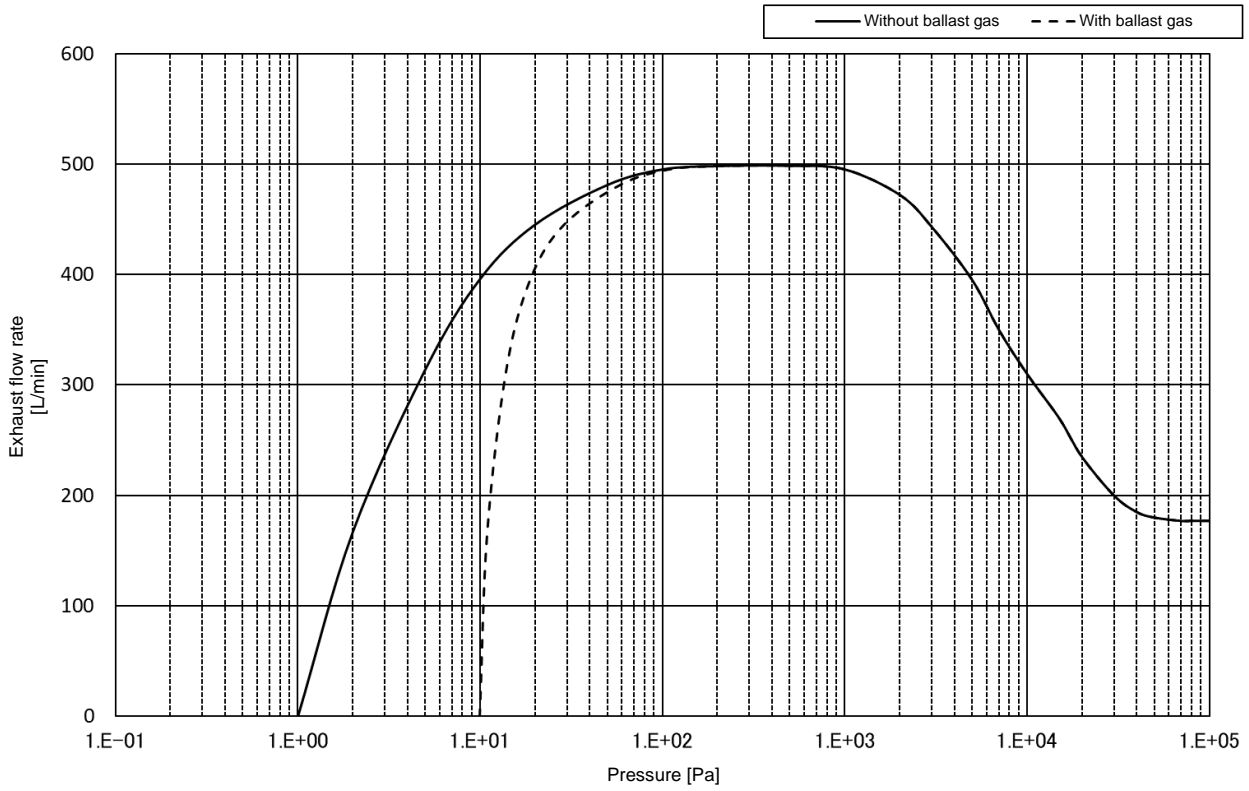

Fig. 3.23

■ NeoDry36G

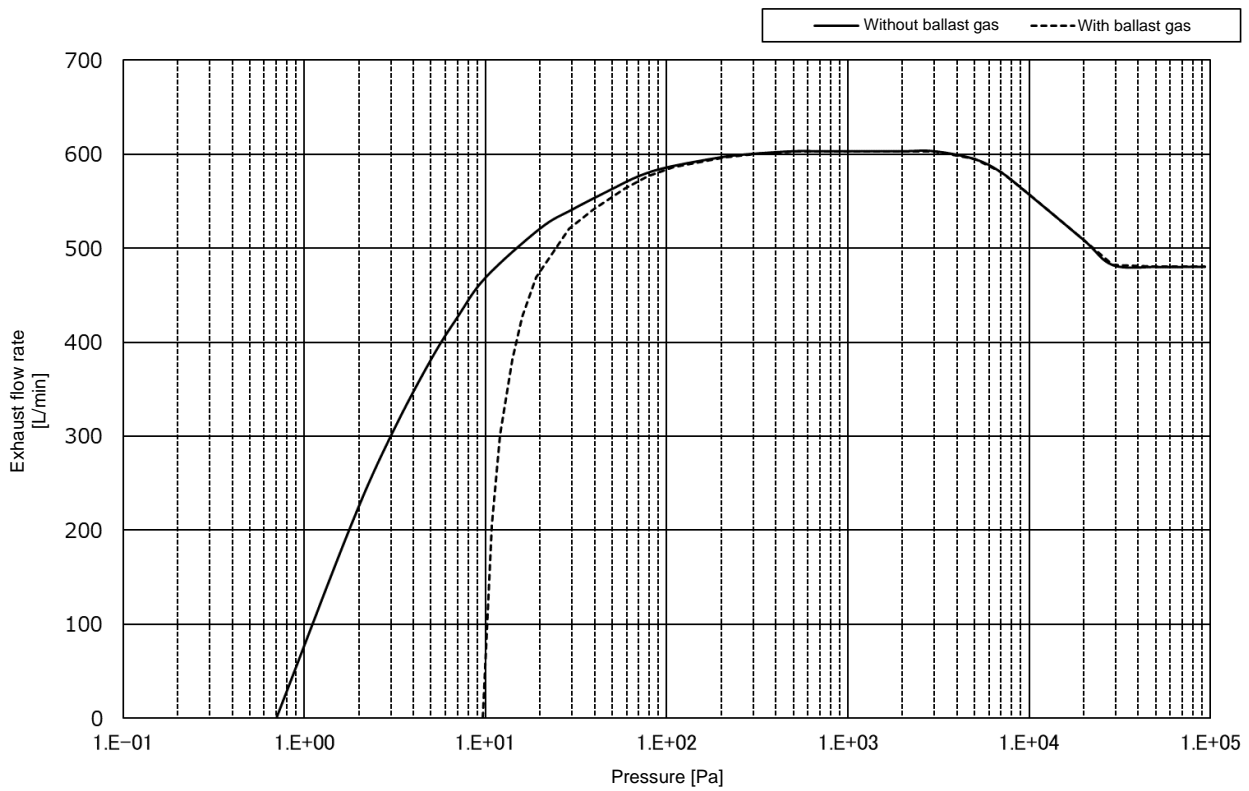

Fig. 3.24

4 Pump Installation

When incorporating the Pump into the user's equipment, it is helpful to mount valves and pipes in advance depending on maintenance and inspection requirements.

When using pipes and sealing parts, select those with sufficient corrosion resistance.

4.1 Installation

⚠ WARNING

	Do not enter the area below hoisted Pump. * Otherwise, bodily injury could be caused by a falling article.
	Pump lifting can only be conducted by personnel qualified for machine operation, including forklifts and cranes. Pay attention to safety. (For NeoDry36G only) * Otherwise, bodily injury could occur.

⚠ CAUTION

	Do not step on the Pump or place articles on it. * Otherwise, bodily injury resulting from rolling-over and failures of the Pump could occur.
	Do not lift the Pump by putting a belt on the handle. When lifting the Pump, two operators shall hold the handle by hand. (NeoDry7G, 15G, 30G) * Otherwise, bodily injury and failures of the Pump could occur.
	Do not install equipment that could be a heat source in front of the Pump. The ventilation gas temperature shall be no greater than the range of Pump operating environment. * Otherwise, failures of the Pump could occur.

■ Lifting procedures (NeoDry36G only)

- 1 When slinging the Pump, use a crane and wires that are suitable for the Pump weight.
- 2 Set the wire to the eyebolt [1] (M8x2)
- 3 When slinging the Pump, the slinging wire angles shall be equal so that load is distributed evenly.
 - The slinging angle shall be no greater than 60°.

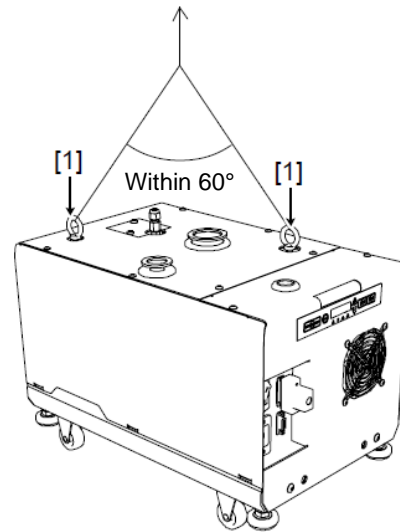

KA00029

4.2 Installation Conditions

■ Installation location

- The Pump is a heavy object. To facilitate maintenance activities, install the Pump on the floor or on a sufficiently rigid frame.
- Install the Pump indoors.
- Fix it on a flat and level foundation floor or on a sufficiently rigid frame with the inlet port and the exhaust port facing up.
- Construct the foundation in a way so that it can sufficiently withstand load and vibration.
- Install it in a place at an altitude of 2,000 meters or lower.
- Install it in a place with the environmental contamination level 2.

Do not install the Pump in the following locations:

- (a) Outdoors, locations subject to water splashing, or locations with extremely high humidity (80% or higher).
- (b) Location exposed to hazardous gases, including acid and alkaline gases.
- (c) Locations exposed to explosive and inflammable gases.
- (d) Locations exposed to rain, snow, ice and dust.

■ Transfer

- When moving the Pump, move it on a carrier, dolly or other transportation equipment.
- When moving the Pump by pushing it with casters, push it in a longitudinal direction. Pushing it crosswise could result in the Pump falling over. When moving it on the location with steps, move it on a carrier or a dolly.

■ Space for installation

⚠ CAUTION



When installing the Pump, for cooling purposes maintain space for ventilation; 100 mm or greater in the front and back, and 50 mm or greater on either side.

* Otherwise, failures of the Pump could occur.

- For smooth installation, maintenance and inspection, install the Pump by keeping appropriate space around it so that installation, maintenance and inspection can be done smoothly.
- Consider that the ambient temperature in operation is within the operating environment temperature and humidity. Pay special attention when operating the Pump in a closed room.

■ Pump Installation

- Install the Pump in a location meeting the installation conditions since the it could vibrate.

■ Pump fixing

- To prevent the Pump from moving, fix it with brackets.
For fixing locations, refer to the following pages.
(The pump brackets are optional parts. Prepare M8 (NeoDry7G, 15G, 30G) and M10 (NeoDry36G) bolts and nuts)

4.2.1 NeoDry7G Pump Fixing Location

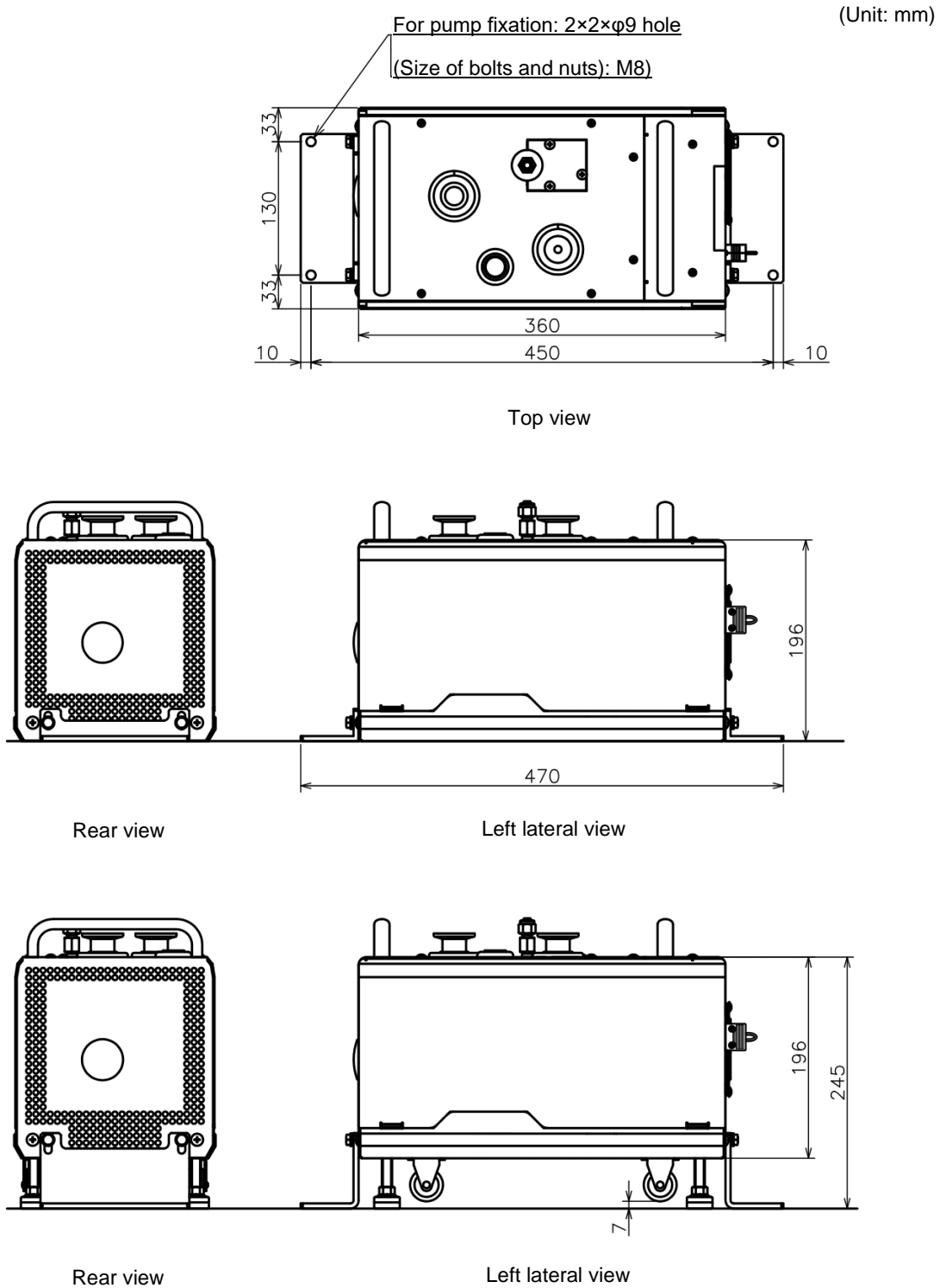

Casters and adjusters are optional parts.

Fig. 4.1

4.2.2 NeoDry15G Pump Fixing Location

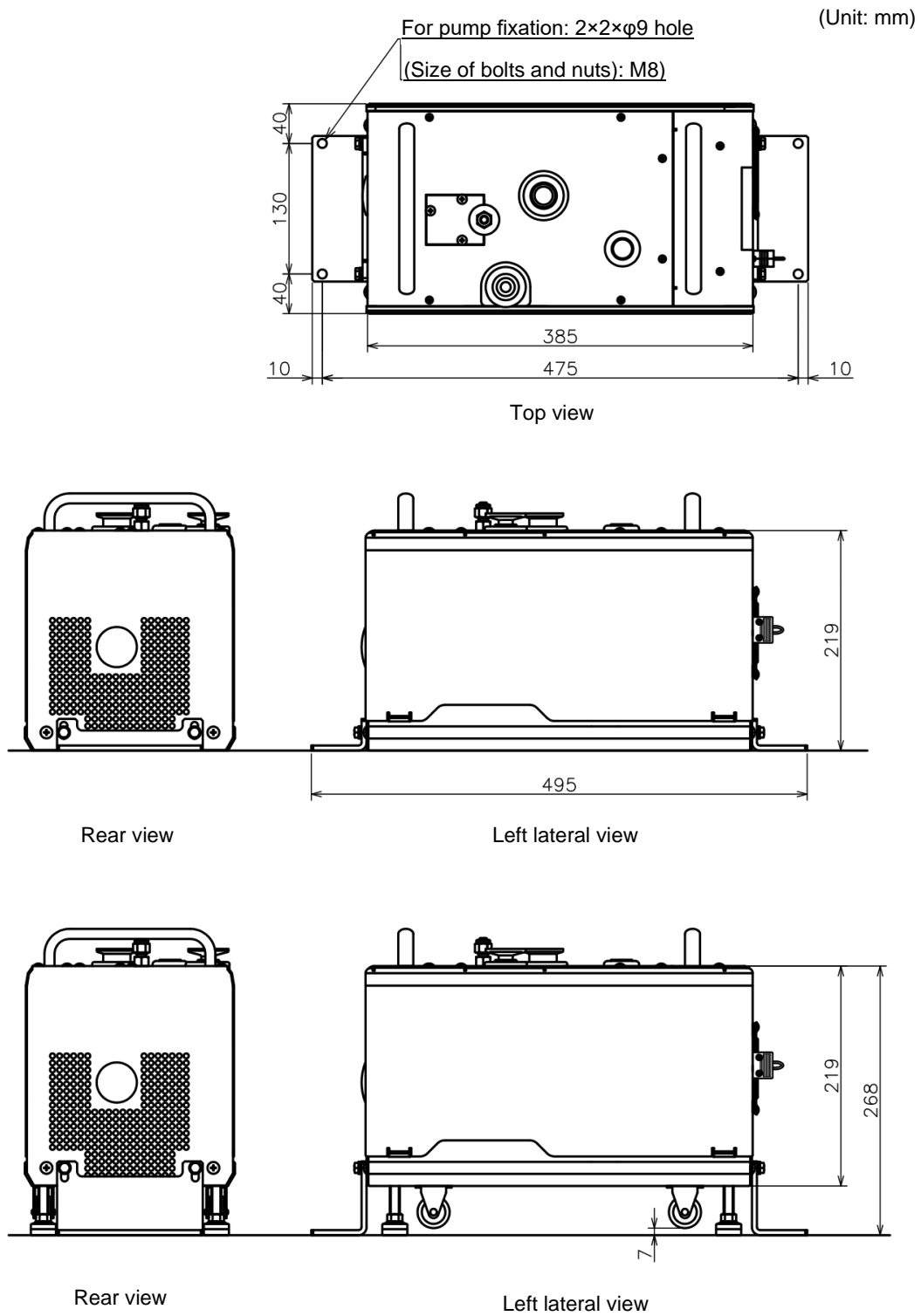

Casters and adjusters are optional parts.

Fig. 4.2

4.2.3 NeoDry30G Pump Fixing Location

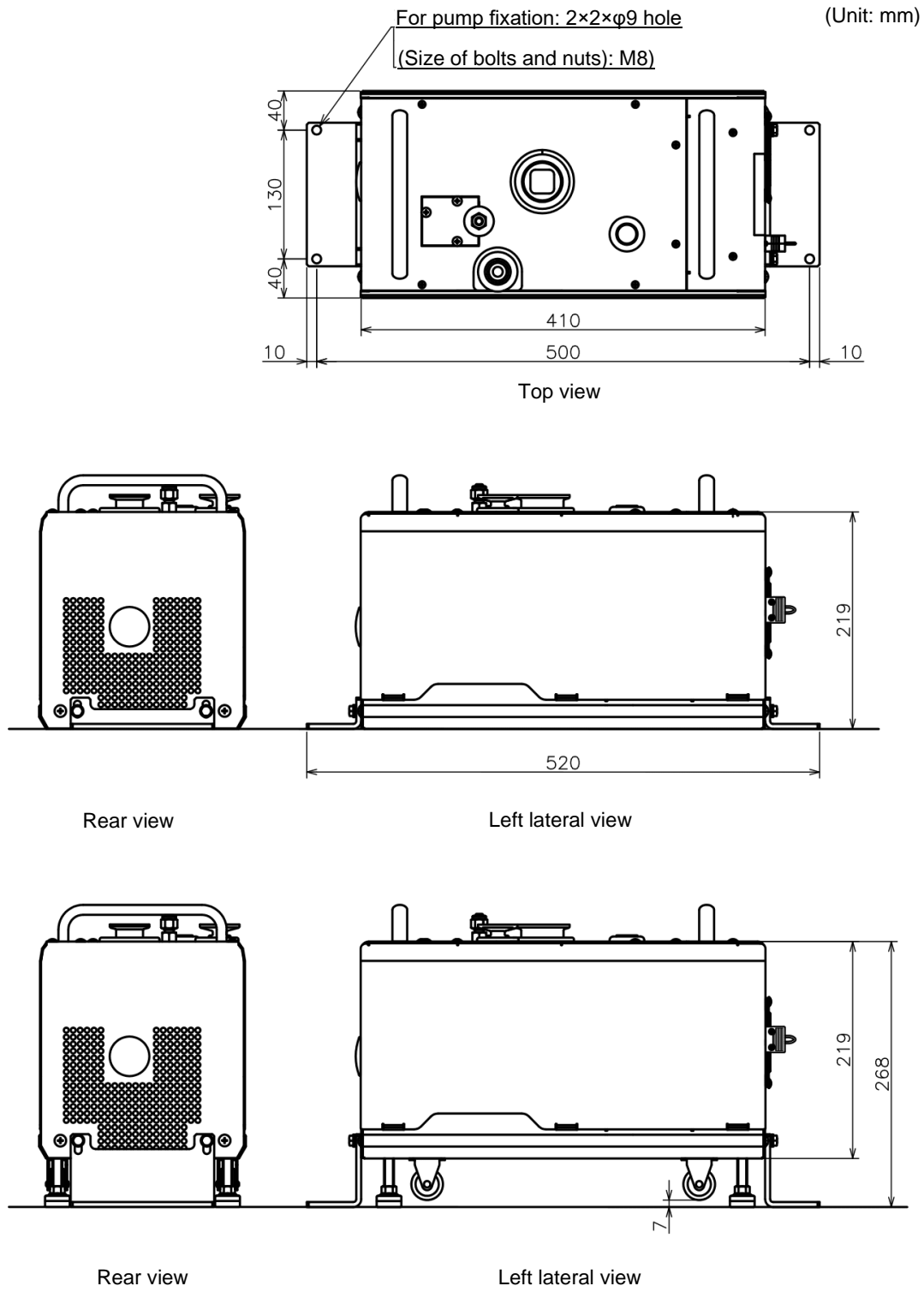

Casters and adjusters are optional parts.

Fig. 4.3

4.2.4 NeoDry36G Pump Fixing Location

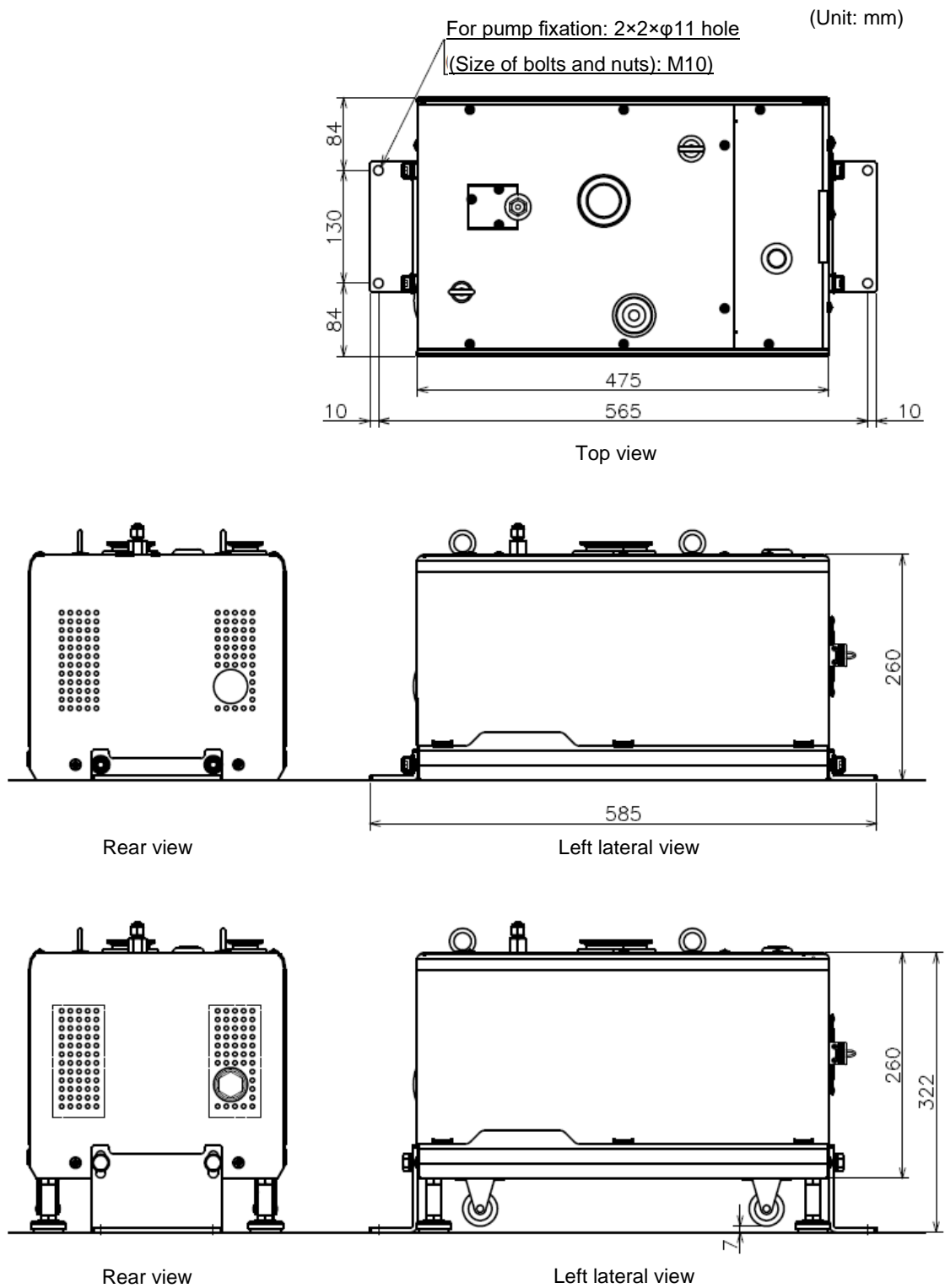

Casters and adjusters are optional parts.

Fig. 4.4

4.3 Pipes

4.3.1 Vacuum and Exhaust Pipes

Connect the vacuum and exhaust pipes to the inlet port and exhaust port.
Connect to the target pipes or parts.

⚠ WARNING



The inlet port and vent pipes of the Pump could become hot. Pay attention not to allow them to contact combustible objects or a human body.

* Otherwise, bodily injury and fire could occur.

⚠ CAUTION



Do not place heavy articles directly on the inlet port or exhaust port.

* Otherwise, leaks from a joint or failure of the Pump could occur.



For pipes and parts on both the inlet and exhaust side, use materials with sufficient resistance to corrosion for safe operation.

* Otherwise, failures, Pump leaks, as well as bodily injury, could occur.

- Do not use pipes with foreign objects.
- It is recommended to use flexible stainless-steel pipes to connect to the Pump inlet port and exhaust port. If there are areas with a particularly low operating pressure (a pressure lower than that in the medium vacuum area), use vacuum pipes.
- Do not allow dirt or dust to adhere to the sealing surface of the quick flange, and do not scratch it.
- To maintain the pumped system vacuum when the Pump has stopped, install a vacuum shut-off valve between the Pump and the pumped system.
- If there is a risk of dust being vacuumed, install a dust precipitator and a filter between the Pump and the pumped system.
- Pay special attention to minimize the resistance of piping, etc., so that exhaust port side pressure (back pressure) will be 3 kPa or less.

4.4 Electrical Wiring

This Pump is not equipped with an electric leakage circuit breaker (ELB) or an emergency OFF switch (EMO). It is necessary to install these in accordance with the laws, regulations and standards of the area of installation. If installation is necessary, install and operate the Pump with an earth leakage circuit breaker equivalent to the following specifications.

Table 4.1 Power source and circuit breaker capacity

Model		NeoDry7G	NeoDry15G	NeoDry30G	NeoDry36G
Power source [50/60 Hz]		100 - 240 V			
ELB	Rated voltage	250 V			
	Rated current	10 A		15 A	
	Rated current sensitivity	30 mA			

WARNING



When conducting wiring and maintenance work, be sure to check that power is not supplied.

* Otherwise, an electric shock could occur.

Electric wiring shall only be conducted by qualified workers.

* Otherwise, bodily injury and fire could occur.

CAUTION



Do not conduct withstand voltage tests.

* Otherwise, instruments could fail or deteriorate.

- When using this Pump in the United States, supply power from a UL489 certified circuit breaker or a branch circuit protected with a certified fuse.
- When using this Pump in Europe, supply power from an IEC60947-2 certified circuit breaker or a branch circuit protected with a certified fuse.
- For the Pump wiring method, refer to the laws and regulations of the area of use.

4.4.1 Power Cabling (Connector code: CN1 (power connector))

WARNING



Be sure to ground the Pump.

* Otherwise, an electric shock could occur.

- Prepare power cables according to the ratings and dimensions stated in Table 4.2.
- Wire power cables correctly, so that they will not be stepped on or become disconnected if pulled. The Pump will stop if the power cables are disconnected.

Table 4.2 Specifications of CN1 receptacle

Model			NeoDry7G · 15G · 30G	NeoDry36G
Pump side	Receptacle	Model	IEC 60320-C14	IEC 60320-C20
Power supply side	Compatible plug	Model	IEC 60320-C13	IEC 60320-C19
		Voltage	250 V	
		Current	10 A (EUROPEAN)	16 A (EUROPEAN)
	Compatible wires	Dimensions	AWG# 16(1.25mm ²) or greater	
			15 A (UL/CSA)	20 A (UL/CSA)

4.4.2 Wiring for Control Power (Connector code: CN2 (I/O connector))

When using the remote control to monitor, follow the following procedures to wire the I/O connector (CN2).

For pin connection, refer to Fig. 4.5 and 4.6 and Table 4.3.

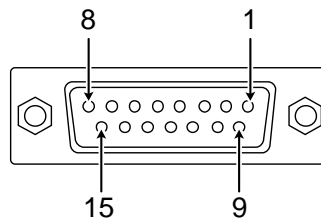

KA00043

Fig. 4.5
I/O Connector (CN2) pump side receptacle

Table 4.3 Specifications of I/O connector (CN2) receptacle

Receptacle type	DA-15SF-N
Screw lock	D20418-J3F (Screw size: M2.6)
Connector manufacturer	Japan Aviation Electronics Industry, Ltd.
(*1) Adaptable plug	DA-15PF-N
Clamp hood	DA-C8-J10-F1-1
Applicable wire size	AWG #24-20 (0.2-0.5 mm ²)

*1 The adaptable plug and clamp hood are not included. Please arrange the these yourself.

⚠ CAUTION



In the case of input signals (Pins No. 1-9, 2-10, 3-11, 4-12), DC24V is applied on the inverter side. Do not apply voltage from the user's equipment.

* Otherwise, failures of the controller could occur.

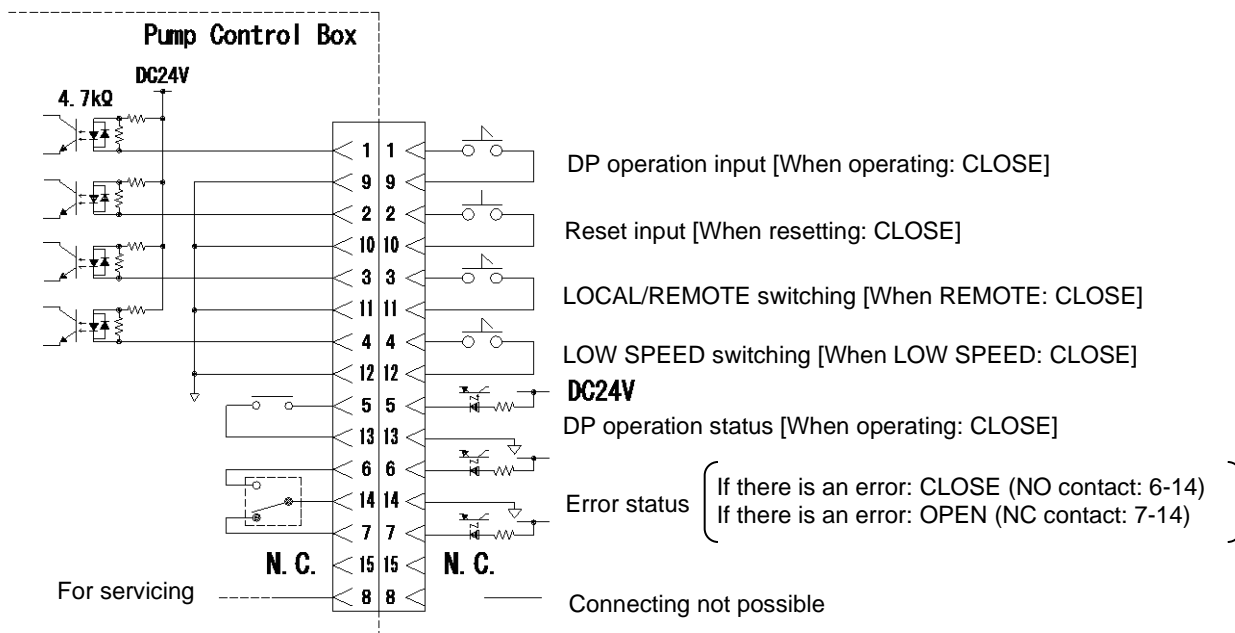

KA00048

Fig. 4.6 I/O Connector (CN2) D-sub receptacle connection diagram

- Output signal (Pins No. 5-13) are contact relay outputs. Contact capacity is DC24V/0.3A.
- Output signal (Pins No. 6-14, 7-14) is 1c contact relay output. Contact capacity is DC24V/0.3A.
- "Close" for at least 0.1 seconds for the reset input signal (Pins No. 2-10).
- Use shielded cables to prevent EMC noise.
Route the shield ends into connector shells.
- The error status output signal will, if there is no power supplied to the Pump, always become (Pins No. 6-14: OPEN, Pins No. 7-14: CLOSE).
(If the Pump power supply stops when an error status signal is being output, the status will be switched to normal)

4.4.3 Wiring for Serial Communication (Connector code: CN3 (serial communication connector))

- When conducting a serial communication, to wire to the serial communication connector (CN3), follow the following procedures:
- For pin connection, refer to Fig. 4.7 and Table 4.4.
- For EMC noise prevention, use shielded twisted pair cables.
- Route the shield ends into connector shells.
- For serial communication wiring details and communication procedures, refer to the attached "Communication Specifications."

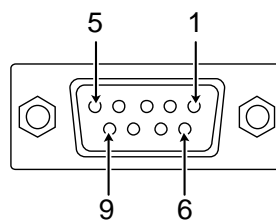

KA00044

Fig. 4.7 Serial communication connector (CN3) pump side receptacle

Table 4.4 Specifications of serial communication connector (CN3) receptacle



Receptacle type	DE-9SF-N
Screw lock	D20418-J3F (Screw size: M2.6)
Connector supplier	Japan Aviation Electronics Industry, Ltd.
(*1) Adaptable plug	DE-9PF-N
Clamp hood	DE-C8-J9-F1-1R
Applicable wire size	AWG #24-20 (0.2-0.5 mm ²)

*1 The adaptable plug and clamp hood are not included. Please arrange these yourself.

4.4.4 Wiring for Valve Controlling (Connector code: CN-SV (valve control connector))

The valve control connector supplies power to isolation valves used to maintain the vacuum state in the pumped system after the Pump has stopped. For valve control, wire to the valve control connectors as follows.

For pin connection, refer to Fig. 4.8 and 4.9 and Table 4.5. For connector locations, refer to "3.5 Names of each part."

⚠ CAUTION	
	<p>Do not connect valves that exceed the power source capacity.</p> <p>* Otherwise, failures of the Pump and electrical devices could occur.</p>
	<p>Do not short-circuit the output of valve control connectors.</p> <p>* Otherwise, failures of the Pump and electrical devices could occur.</p>
	<p>Remove the attached grommet when wiring to the valve control connector.</p> <p>Be sure to install the grommet when the valve control connector is not wired.</p> <p>* Otherwise, failures of the Pump could occur.</p>

- After the Pump starts and reaches a certain rotation speed, DC24 will be output. When the pump stops, the pump RPM lowers, pump errors occur and power failures occur, the output will stop.

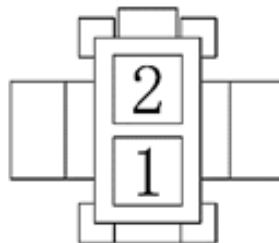

KA00045

Fig. 4.8 Valve control connector (CN- SV) pump side receptacle

Table 4.5 Specifications of the valve control connector (CN- SV) receptacle

Receptacle type	5559-02P-210
Contact type	5558TL
Connector manufacturer	Molex Incorporated
Power capacity	DC 24 V, 0.5 A
(*1) Adaptable plug	5557-02R-210
(*1) Adaptable contact	5556TL
Applicable wire size	AWG #24-20 (0.2-0.5 mm ²)

*1 The adaptable plug and contact are not included. Please arrange the these yourself.

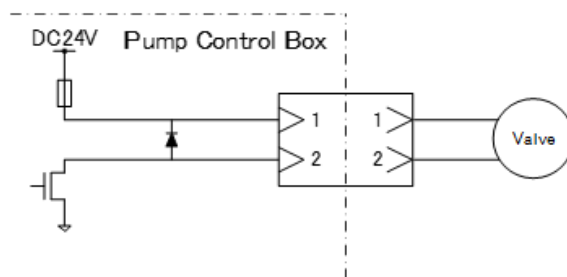

KA00046

Table 4.9 Valve control connector (CN- SV) receptacle connection diagram

5 Operating Panel

5.1 Operating Panel

The Pump operating status can be confirmed by viewing the operating panel LED indicator on the Pump main unit operating panel.

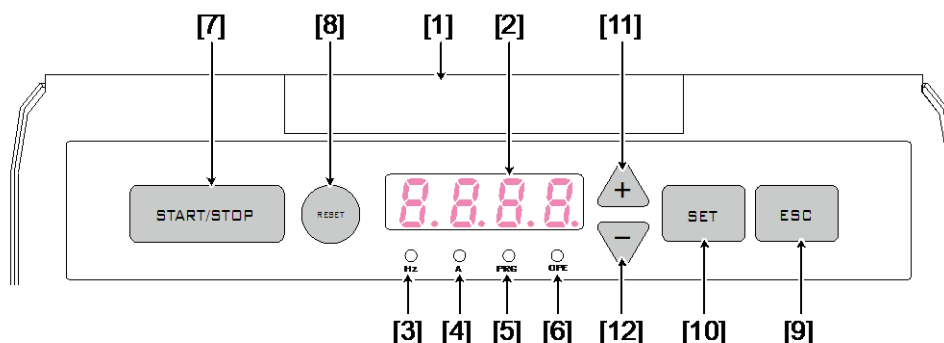

KA00025

Fig. 5.1

Table 5.1 Explanation of the operating panel

No.	Name	Contents
[1]	Status bar	<p>Indicates the state of the Pump</p> <ul style="list-style-type: none"> Power OFF : Turns OFF Power shut-down : Turns ON in white In operation : Turns ON in green In LOW SPEED operation : Flashing in green (the interval between ON-OFF is the same) Overhaul recommendation 1 : Flashing in green (Repeating long ON and short OFF) *1 Overhaul recommendation 2 : Flashing in green (Repeating "long ON->short OFF->short ON->short OFF") *2 When stopped : Turns ON in blue An alarm has been triggered : Turns ON in red
[2]	LED display	Displays operating hours, operating frequencies, electric current, etc.
[3]	Monitor lamp (Hz)	When the LED display is indicating frequency data, this turns ON in white.
[4]	Monitor lamp (A)	When the LED display is indicating current data, this turns ON in white.
[5]	Program lamp	When data on the LED display is changeable, this turns ON in white.
[6]	LOCAL/REMOTE lamp	Turns ON in white when LOCAL is in operation and turns OFF when REMOTE is in operation.
[7]	START/STOP switch	Pump run or stop
[8]	RESET switch	Error reset, overhaul recommendation display cancel *3
[9]	ESC switch	Switches LED display and group code.
[10]	SET switch	Switches displayed data and contents.
[11]	UP switch	Operation of data display
[12]	DOWN switch	

*1 This is displayed when the operating hours since the last overhaul exceeds 17,500.

*2 This is displayed when the operating hours since the last overhaul exceeds 26,000.

*3 When an overhaul recommendation is displayed, flashing can be cancelled by pressing the reset switch longer than usual.

(Continue to press the reset switch until the LED display indicates " ! ! ! ! ")

After the display is cancelled, press the reset switch again for longer than usual or restart the Pump after it has stopped. The overhaul recommendation display will then be indicated again.

5.2 LED Display

Use this LED display to confirm the Pump status and to set and confirm the Pump control details. A 4-digit number is displayed on the screen. The leftmost character indicates the group code.

5.2.1 List of Group Code

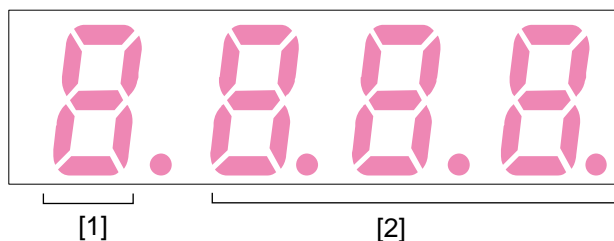

KA00027

Fig. 5.2

Table 5.2 Contents of LED Display

Group code [1]	Contents of LED Display [2]	Operation
<i>d</i> - - -	Operating data monitor	Operating data can be displayed
<i>A</i> - - -	Inverter setting 1	Inverter settings can be displayed/changed
<i>b</i> - - -	Inverter setting 2	Operation prohibition
<i>C</i> - - -	Inverter setting 3	Inverter settings can be displayed/changed

5.2.2 Operational Procedures

When switching the LED display, refer to the following illustrations:

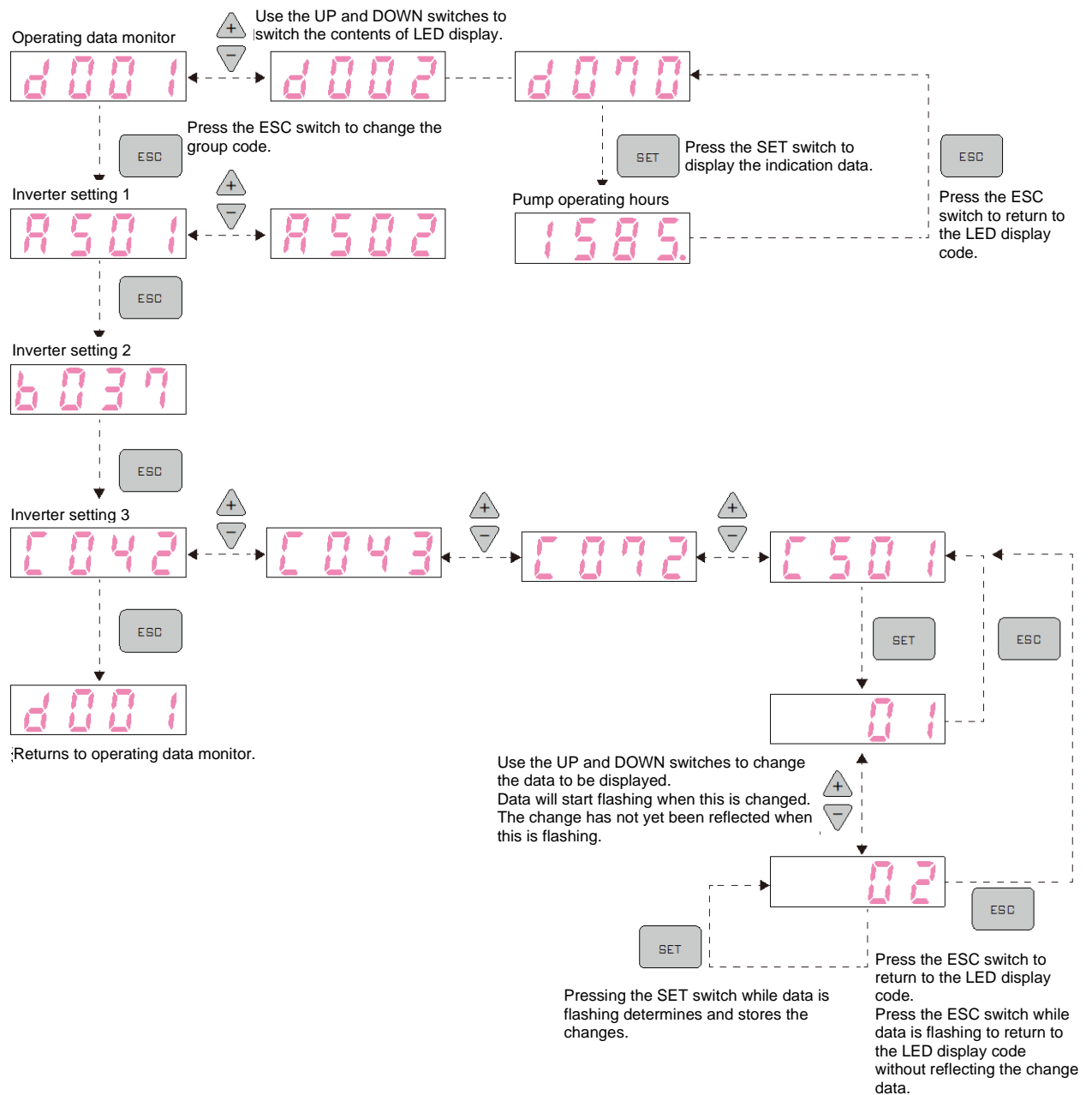

* Pump operation hours are displayed when the power is turned ON.

KA00028

Fig. 5.3

5.2.3 List of Contents of LED Display

LED display code	Indicated contents	Unit	Contents
d001	Operating frequency	Hz	The operating frequency is indicated. While the contents are being indicated, the monitor lamp (Hz) will turn ON.
d002	Secondary side current	A	The secondary side current value is indicated. While the contents are being indicated, the monitor lamp (A) will turn ON.
d070	Cumulated pump operating hours	Hours	Indicates the cumulated pump operating hours. (*1)
d073	Operating hours after overhaul	Hours	Indicates the operating hours since last Pump overhaul. (*1)
d080	Count of occurred errors	Times	Indicates the count of occurred errors. (*2)
d081 to d088	Content of Error	–	The contents of the past eight errors can be confirmed. (*3) (When there are no errors, - - - - will be indicated)
A501	Commanded frequency	Hz	Indicates and sets the commanded frequency. (*4) While the contents are being indicated, the monitor lamp (Hz) will turn ON.
A502	Commanded low speed frequency	Hz	Indicates and sets the low speed commanded frequency. (*4) While the contents are being indicated, the monitor lamp (Hz) will turn ON.
C042	Valve operation start frequency when accelerating	Hz	Indicates and sets the operating frequency at which valve operation starts. (*5) While the contents are being indicated, the monitor lamp (Hz) will turn ON.
C043	Valve operation end frequency when decelerating	Hz	Indicates and sets the operating frequency at which the valve operation ends. (*5) While the contents are being indicated, the monitor lamp (Hz) will turn ON.
C072	Slave address	–	Indicates and sets the Modbus communication slave address. (For details, refer to attached "Communication specifications)
C501	Operating command selection	–	Indicates and sets the operating and stopping procedures. [00] : Run/Stop using external signals. [01] : Run/Stop using an operating panel. [02] : Run/Stop using serial communication. * When inputting external signals for "Switching of LOCAL/REMOTE," regardless of this setting, Run/Stop are conducted by external signals.

■ Example of LED display on the operating panel (*1, *2)

Indicated contents	Scope of data	Contents	Example of LED display	Operating hours, frequency
(*1) Total Pump operating hours Operating hours since O/H	0.0 to 999.9	Indicated in 0.1-hour increments.	333.3	333.3 hours
	1000. to 9999.	Indicated in 1-hour increments.	3333	3,333 hours
	1000 to 9999	Indicated in 10-hour increments.	3333	33,330 hours
	┌100 to ┌999	Indicated in 1000-hour increments.	┌3333	333,000 hours
(*2) Count of occurred errors	0. to 9999.	Indicate in the unit of once	3333	3,333 times
	1000 to 6553	Indication in the unit of 10 times	3333	33,330 times

■ Switching of error message indications (*3)

The error messages can be confirmed.

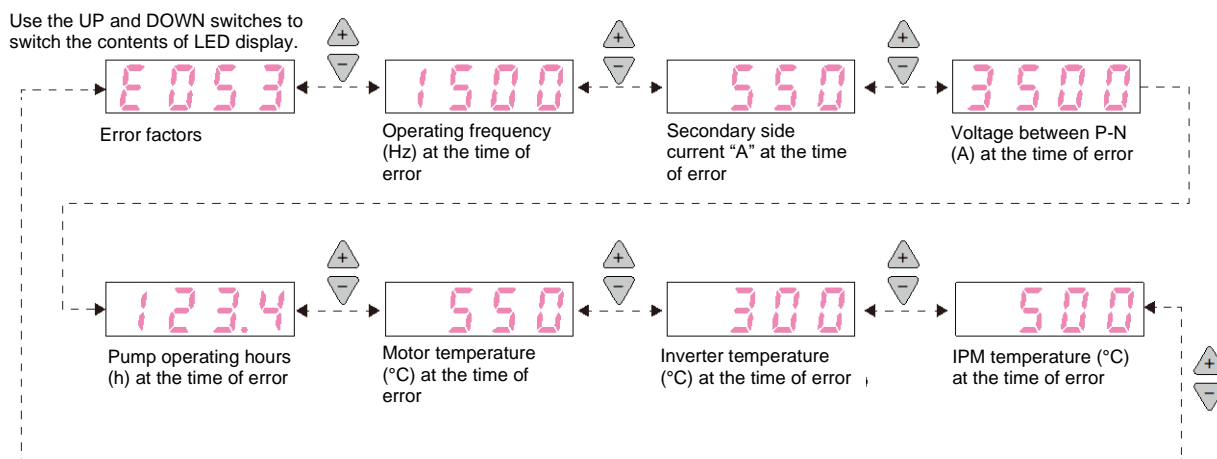

KA00042

Fig. 5.4

■ The range in which frequency setting is possible (*4, *5)

Model	The range in which setting is possible	
	Commanded frequency (*4)	Valve operation frequency (*5)
NeoDry7G	125 to 190 [Hz]	0 to 300 [Hz] * 0: Function disable
NeoDry15G	125 to 245 [Hz]	
NeoDry30G	125 to 245 [Hz]	
NeoDry36G	100 to 180 [Hz]	

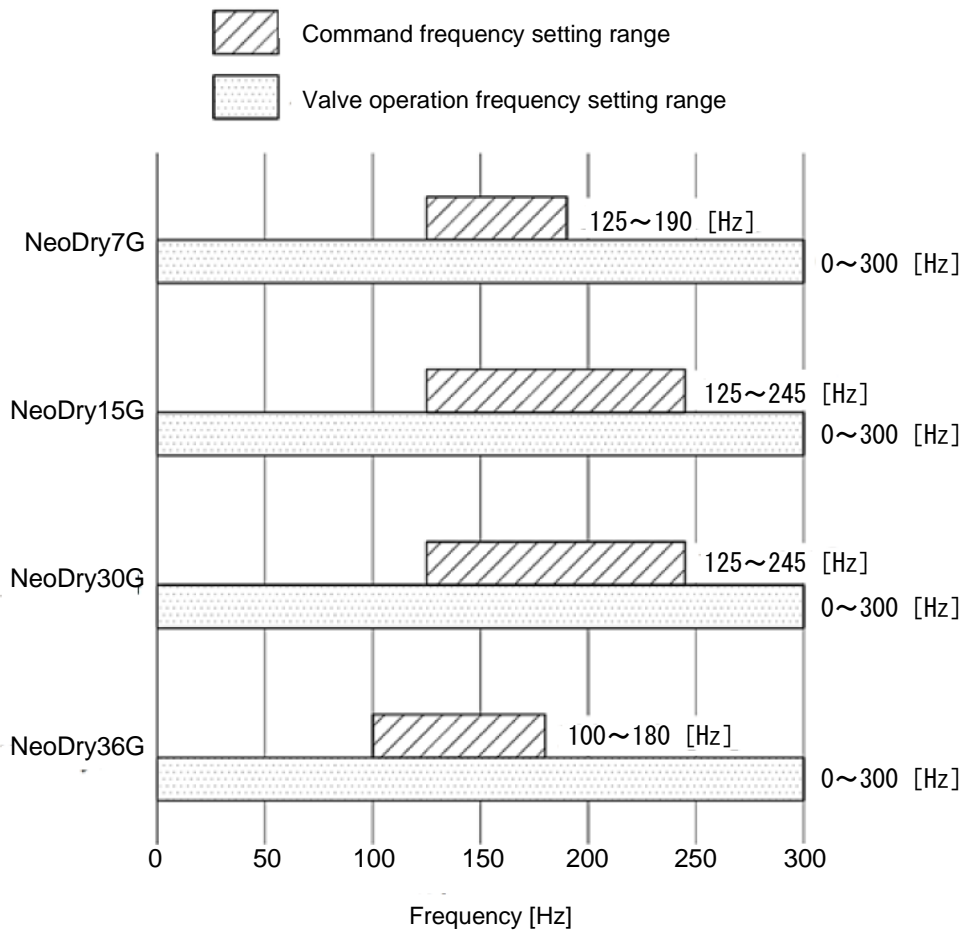

Fig. 5.5

KA00047

NOTICE

- The valve operating frequency cannot be changed when the Pump is in operation. After making changes, be sure to check operation.
 If the ending frequency is set greater than the starting frequency, or the starting frequency is set smaller than the ending frequency, the earlier set parameters will be rewritten by the later set parameters. If both the earlier and later parameters are close to each other, valve operation could chatter.

6 Operation and Stop

Pump operation can be selected from several modes; "operation using operating connectors (direct-on-line operation), "operation using an operating panel," "operation using external signals" and "operation using serial communication."

6.1 Operation Preparation

Confirm the following before operating.

- 1 Electrical wiring is securely connected.
- 2 The inlet port and exhaust pipes are correctly connected.
If valves are installed to the exhaust side, be sure to open the valves before starting.
- 3 Pump ventilation is sufficient.

6.2 Operation and Stop

⚠ WARNING



These parts are hot during operation and could stay hot for a while after the Pump has stopped.

Conduct maintenance work after the Pump has sufficiently cooled down while paying attention not to allow it to contact combustible objects or a human body.

* Otherwise, fire or burns could occur.

⚠ CAUTION



Do not disassemble the enclosure.

* Otherwise, the Pump could fail or diminish in performance.



When exhausting condensable gas, be sure to use the multi-gas ballast mechanism (option) to take in the ballast gas for operation.

* Otherwise, failures of the Pump could occur.

Before supplying power, check that the inlet and exhaust pipes are correctly connected.

If power is supplied to the Pump while the pump ON signal is input, it will start to operate immediately.

Take safety measures to prevent errors upon start of the Pump.

* Otherwise, bodily injury and failures of the Pump could occur.

When operation repeatedly starts and stops, operate the Pump by external signal changing or a serial communication.

* Otherwise, the inverter life will become shorter and failures could occur.

NOTICE

- Sufficient warm-up is necessary to achieve exhaust performance (achieved pressure and exhaust speed) that satisfies Pump specifications.
- As necessary, close the shut-off valve on the Pump inlet port side.
(To keep the pumped system vacuumed while the Pump is stopped, install a vacuum shut-off valve between the pumped system and the Pump and close this valve before stopping the Pump)
- When condensable gases (a mixture of water vapor and solvent) are exhausted, operate the Pump for about one hour after exhausting while opening the inlet port. Then, stop the Pump. This process to replace the gases exhausted stagnating inside the Pump with dry air is necessary in order to prevent the inside of the Pump from becoming corroded. The larger the amount of exhausted gas, the longer the required time for pump operation.
- If there is an ON-OFF valve on the exhaust port side, close the valve as necessary after exhausting.
- When operating using operating connectors (direct-on-line operation), pressing the START/STOP switch on the operating panel will stop the Pump.
To resume operation, turn OFF the power supply once (LED display and status bar on the operating panel turns OFF), and then press the START/STOP switch again. Operation will restart immediately.
- When operating using external connectors, pressing the START/STOP switch on the operating panel will stop the Pump.
To resume operation, open the "DP operating input" of the I/O connector (CN2) (short circuiting the Pin No. 1-0), and then start input again (short circuiting the Pin No. 1-9).
- Operation using external signals is not possible if "LOCAL/REMOTE switching" of the I/O connector (CN2) is open (Pin No. 3-11 is open). The operating panel needs to be used for operation.
- If the "LOW SPEED switch" of the I/O connector is short circuited (short circuiting the Pin No. 4-12), the operation mode will be switched to LOW SPEED regardless of the operating method (operating panel, external signal, serial communication).

6.2.1 Operation using Operating Connectors (direct-on-line operation)

- When conducting direct-on-line operation, mount the operating connector [1] attached to the I/O connector (CN2).

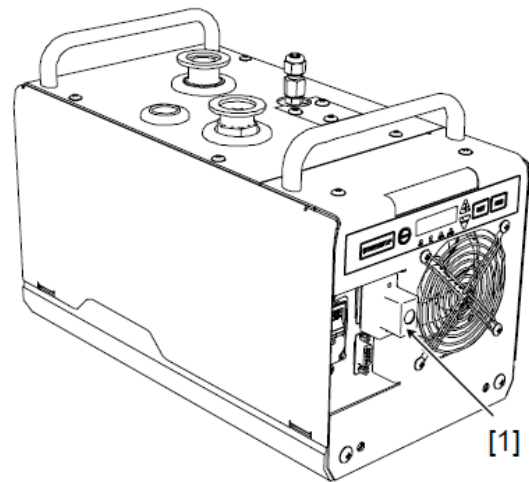

* This illustrates NeoDry7G.

KA00061

Fig. 6.1

■ Start up by supplying primary side power

- 1 Turn ON the main switch [1].

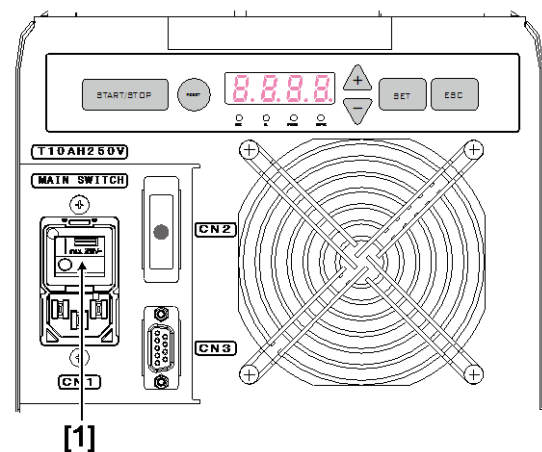

KA00060

- 2 Supply power to the Pump.

→ The pump will immediately start up. The status bar [2] turns ON in white and soon changes its color to green.

→ The LOCAL/REMOTE lamp [3] on the operating panel does not turn ON.

- Power supply procedures to the Pump differ according to user's equipment.

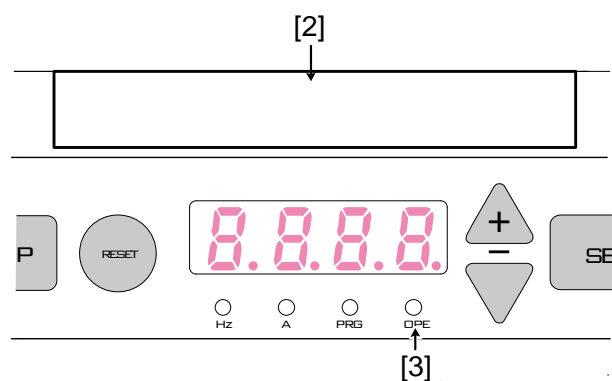

KA00062

- 3 After starting, check that there are no abnormal noises (noises, abnormal vibrations, etc.) in the Pump operation.

■ Stop using power supply on the primary side

1 Stop supplying power.

- The Pump will stop.
- The status bar [2] changes color from green to white and then turns OFF.
 - The procedures to stop power supply to the Pump differs by user's equipment.

■ Start using the main switch

1 Supply power to the Pump.

- Power supply procedures to the Pump differ according to user's equipment.

2 Turn ON the main switch [1].

- The pump will immediately start up.

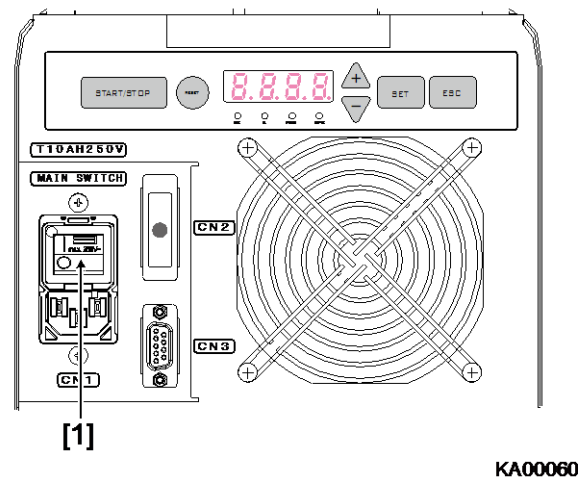

- The status bar [2] turns ON in white and soon changes its color to green.
- The LOCAL/REMOTE lamp [3] on the operating panel does not turn ON.

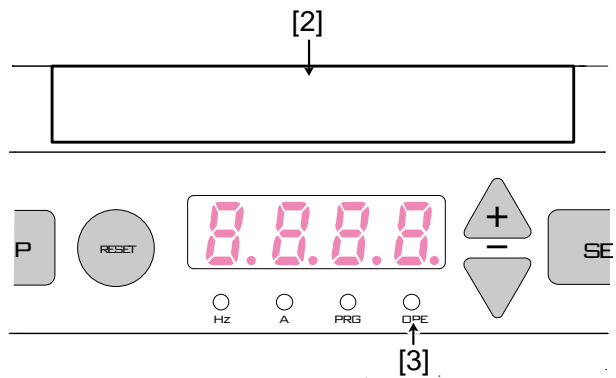

3 After starting, check that there are no abnormal noises (noises, abnormal vibrations, etc.) in the Pump operation.

■ Stop using the main switch

1 Turn OFF the main switch [1].

- The Pump will stop.
- The status bar [2] changes color from green to white and then turns OFF.

6.2.2 Operation Using an Operating Panel

■ Start using an operating panel

When operating using the operating panel, remove the operating connector [1] attached to the I/O connector (CN2).

- 1 Supply power to the Pump and turn ON the main switch [1].
 - Power supply procedures to the Pump differ according to user's equipment.

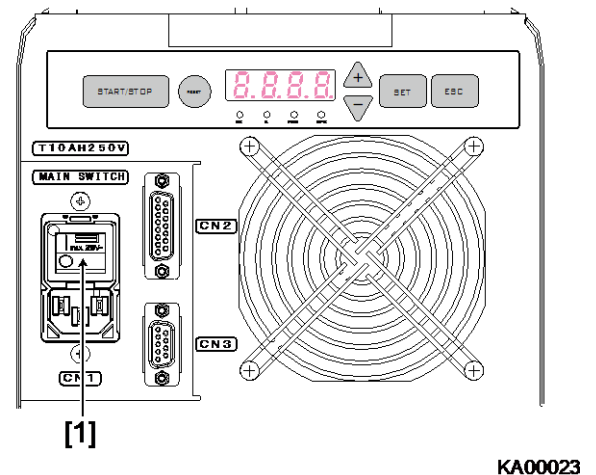

The status bar [2] turns ON in white and soon changes color to blue.

→ The LOCAL/REMOTE lamp [3] on the operating panel turns ON in white.

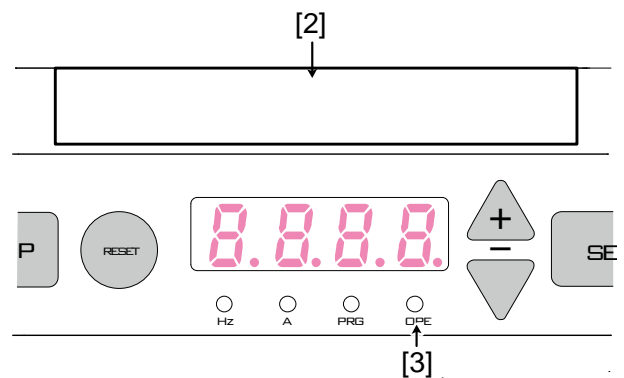

- 2 Press the START/STOP switch [4] on the operating panel.
 - The Pump will immediately start up.
 - The status bar [2] changes its color from blue to green.

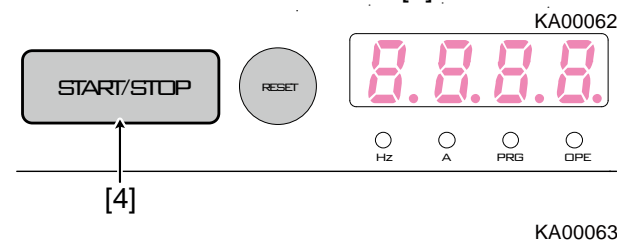

- 3 After starting, check that there are no abnormalities (noise, abnormal vibration, etc.) in the Pump operation.

■ Stop using the operating panel

- 1 Press the START/STOP switch [1].

→ The Pump will stop.

→ The status bar [2] changes color from green to blue.

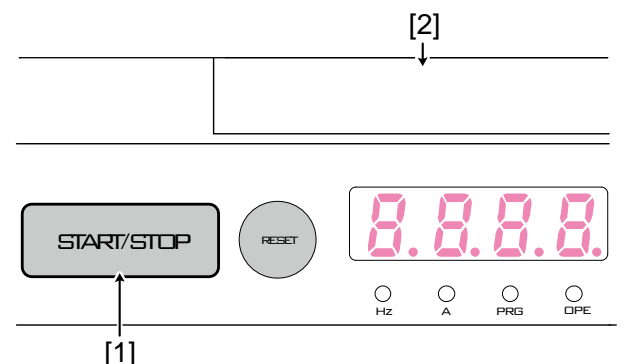

6.2.3 Operation Using External Signals

■ Start using external signals

Connect the control wire to the I/O connector (CN2). (Adaptable plugs and clamp hoods are not included. Please arrange these yourself)

(For details of control power wiring, refer to 4.4.2 Wiring for control)

1 Supply power to the Pump and turn ON the main switch [1].

- Power supply procedures to the Pump differ according to user's equipment.

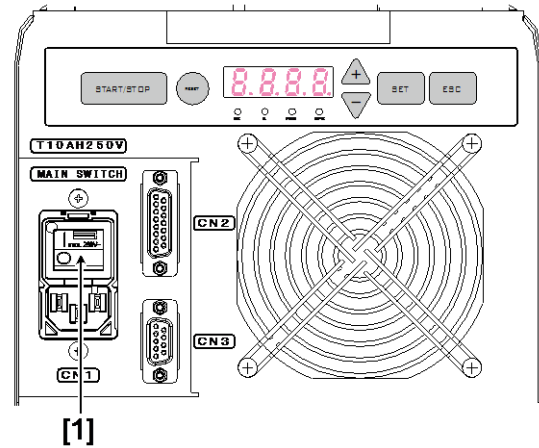

- The status bar [2] turns ON in white and soon changes color to blue.
- The LOCAL/REMOTE lamp [3] on the operating panel turns ON in white.

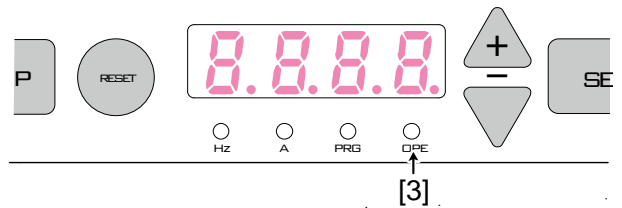
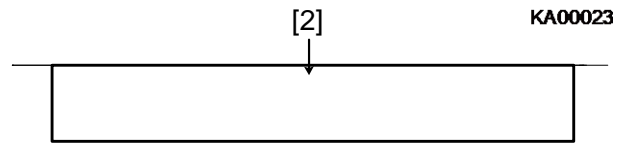

2 Input "LOCAL/REMOTE switch" of the I/O connector (CN2) (short-circuiting the Pins No.3-11).

- The LOCAL/REMOTE lamp [3] on the operating panel turns OFF.

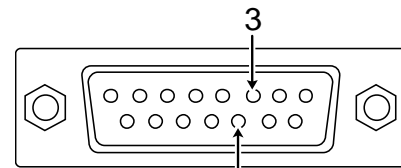

11 (short-circuiting the Pins No.3-11)

KA00067

3 Input (short-circuiting pins no. 1-9) "DP operation input" of the I/O connector (CN2).

- The Pump will immediately start up.
- The status bar [2] changes color from blue to green.
- In addition, "DP operation status" output (Pins No. 5-13) will "close."

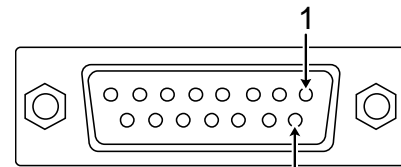

9 (short-circuiting the Pins No.1-9)

KA00068

4 After starting, check that there are no abnormalities (noise, abnormal vibration, etc.) in the Pump operation.

■ Stop using external signals.

- 1 Open (Pins No.1-9 open) "DP operation input" of the I/O connector (CN2).
 - The Pump will stop.
 - The status bar [2] changes color from green to blue.In addition, "DP operation status" output (Pins No.5-13) will "open."

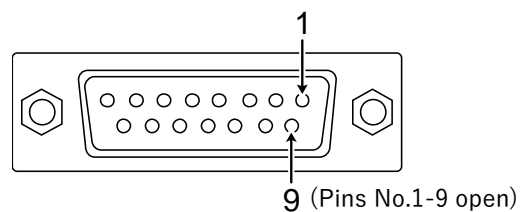

KA00069

6.2.4 Operation Using Serial Communication

For details on operational procedures using serial communication, refer to the attached "Communication Specifications."

6.3 Multi-gas Ballast Mechanism (option)

6.3.1 Type

1 Without flowrate adjustment feature



KA00054A

2 With flowrate adjustment feature



Photo 6.1 Gas ballast type

- There are two types of gas intake system in the multi-gas ballast mechanism; air intake and N2 intake. Select one of these two depending on the gas type to be in-taken. When solvent is to be exhausted, regardless of the type and volume of solvent, contact us at the contact information stated at the end of this operating manual in advance.

6.3.2 Installation of the Multi-gas Ballast Mechanism

Install the multi-gas ballast mechanism if necessary.

(The installation procedures for both types, with or without flowrate adjustment feature, are the same)

- Fix the joint body [1] at the ballast gas inlet part with a wrench and disassemble the 1/4 plug union [2].
- When disassembling, do not disassemble the joint body [1].

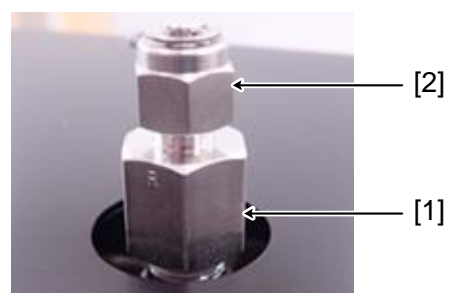

KA00050

- 2 Check that there are no scratches or foreign materials on the tapered surfaces of the joint body [3].

- If there are, it could cause leaks and cause an increase of achieved pressure.



KA00051

- 3 Check that there are no scratches or foreign materials on the front ferrule surface [4] of the multi-gas ballast mechanism.

- If there are, it could cause leaks and cause an increase of achieved pressure.



KA00052

- 4 While pushing the multi-gas ballast mechanism towards the joint body tapered surface, fix with a nut by hand until it stops.

- 5 Fix the joint body [1] with a wrench and fasten the nut [5] for 1/4 turns with the wrench.

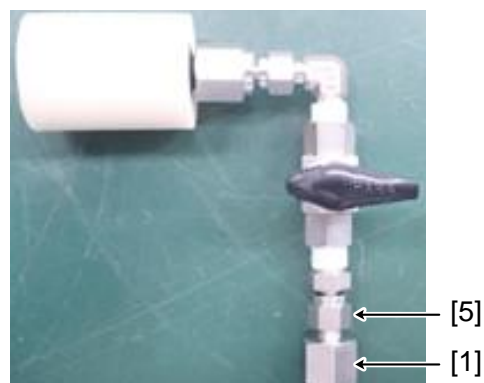

KA00053

Without flowrate adjustment feature

- 6 After mounting, check that there are no leaks from the joint.
- When purchasing the multi-gas ballast mechanism, an air intake type is delivered. When changing to an N2 intake type, disassemble the 1/4 tube fitting [6] of the multi-gas ballast mechanism with a tool and mounting a pipe. (Check that there are no leaks from the joint after mounting.)

Air intake type



N2 intake type

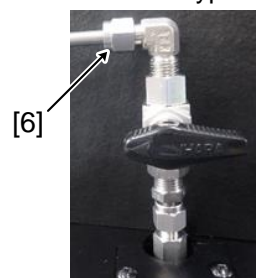

KA00054

Without flowrate adjustment feature

6.3.3 Multi-gas Ballast Valve Open/Close Procedures

Follow the following procedures to open/close the multi-gas ballast valve.

■ Without flowrate adjustment feature

- 1 Turn the multi-gas ballast valve [1] counterclockwise.
→ The multi-gas ballast valve opens.

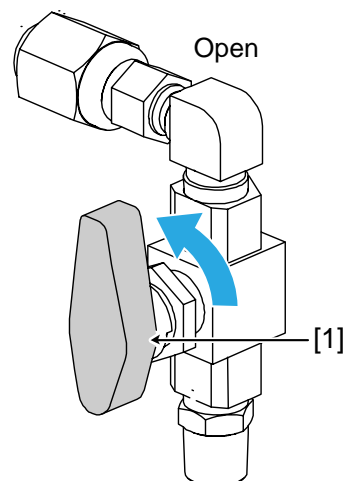

- 2 Turn the multi-gas ballast valve [1] clockwise.
→ The multi-gas ballast valve closes.

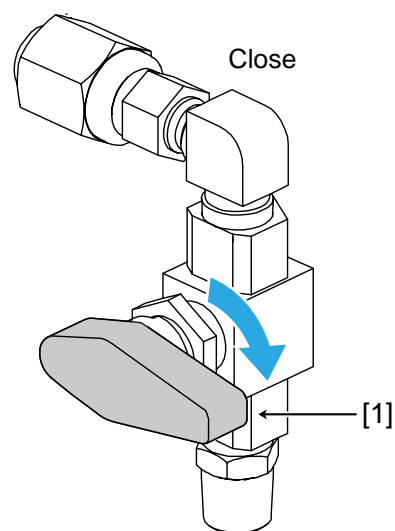

KA00066

KA00055

■ With flowrate adjustment feature

- 1 Turn the multi-gas ballast valve [1] counterclockwise to adjust to the desired opening angle.

→ The multi-gas ballast valve opens.

- 2 After completing the valve opening angle adjustment, tighten the hexagon socket head setscrews (M3) [2] attached to the valve body. Then, confirm the multi-gas ballast valve [1] is fixed.

→ The flowrate of ballast gas supplied to the pump will be fixed at a constant flowrate.

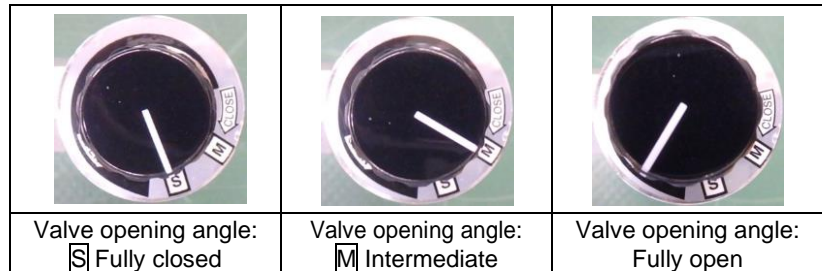
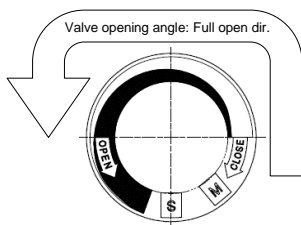
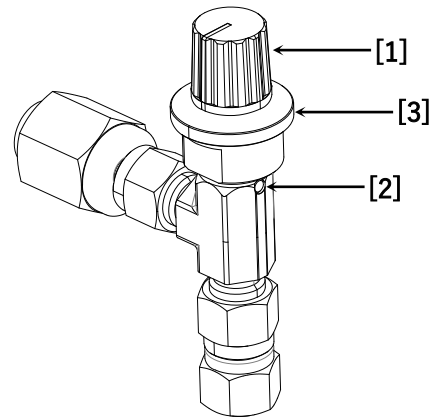

Bonnet nut (valve opening angle indication) [3] details

- 3 Loosen the hexagon socket head setscrews (M3) [2] attached to the valve body.

- 4 Turn the multi-gas ballast valve [1] clockwise.

→ The multi-gas ballast valve closes.

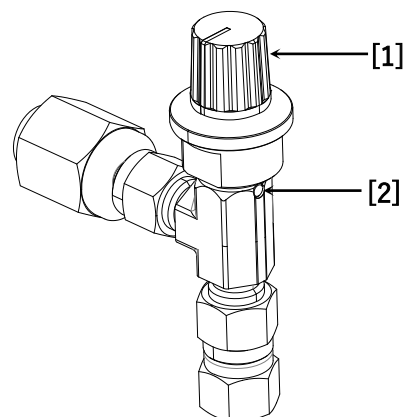

*1 Resin parts are used for valve seat sealing. When closing the multi-gas ballast valve, do not forcibly tighten the valve beyond **S** (fully closed).

*2 If the multi-gas ballast valve is operated while the hexagon socket head setscrews (M3) [2] of the valve body are fastened, the valve could fail.
Loosen the hexagon socket head setscrews (M3) [2] of the valve body before operating the multi-gas ballast valve.

■ Maximum volume of water vapor processing

1 Without flowrate adjustment feature



Model	Maximum volume of water vapor processing
NeoDry7G	135g/h
NeoDry15G	275g/h
NeoDry30G	275g/h
NeoDry36G	350g/h

2 With flowrate adjustment feature

Model	Maximum volume of water vapor processing	
	☐ intermediate	Fully open
NeoDry7G	40g/h	135g/h
NeoDry15G	70g/h	275g/h
NeoDry30G	70g/h	275g/h
NeoDry36G	70g/h	350g/h

- The maximum volume of vapor water processing when multi-gas ballast valve is open.
- When exhausting condensable gases, be sure to use the multi-gas ballast mechanism.

6.3.4 Use

⚠ CAUTION	
	<p>Do not install to the multi-ballast gas inlet part anything other than the optional gas ballast mechanism.</p> <p>* Otherwise, failures of the Pump could occur.</p>
	<p>Do not feed N2 gas, with the maximum feeding pressure of 0.05MPa or greater, to the multi-gas ballast mechanism.</p> <p>* Otherwise, failures of the Pump could occur.</p>
	<p>When condensable gases, including water vapor, is exhausted, do not stop the Pump immediately after exhausting.</p> <p>Before stopping, continue Pump operation for about one hour with the inlet port open.</p> <p>* Otherwise, condensed moisture remaining inside the Pump could cause failures such as corrosion.</p>
	<p>When exhausting condensable gas, be sure to use the multi-gas ballast mechanism (option) to take in the ballast gas for operation.</p> <p>* Otherwise, failures of the Pump could occur.</p>
	<p>When using the multi-gas ballast mechanism to exhaust condensable gas, use the Pump after warming it up sufficiently (after an hour of warming or longer).</p> <p>When the Pump is cold, its “multi-gas ballast treatment capability” will not be fully functional.</p> <p>* Condensation of condensable gases in the Pump room could lead to failures.</p>
	<p>Do not allow condensation within the exhaust side pipe to flow back into the Pump. Condensable gases that do not condense within the Pump could condense within the exhaust side pipe.</p> <p>* Otherwise, failures of the Pump could occur.</p>
	<p>Store the Pump where the inside will remain dry.</p> <p>* Leaving the Pump with the condensable gases, such as water vapor, remaining inside the Pump could cause a turning problem during subsequent startup.</p>
	<p>Be sure to install the Pump in a dust-free environment.</p> <p>The air intake multi-gas ballast type is provided with a filter to avoid foreign materials included in the air do not enter into the Pump while taking air in.</p> <p>If the Pump operates in a dusty environment, foreign materials in the air will adhere to the filter, reducing the flowrate of ballast gas being fed.</p> <p>* Condensation of condensable gases within the Pump could no longer occur, leading to Pump failures.</p>

- If the Pump has stopped with the multi-gas ballast valve in the "open" position, outside air is introduced into the Pump from the multi-gas ballast valve and the vacuum state within the Pump cannot be maintained.
- To exhaust condensable gases (a mixture of water vapor and solvent), operate the Pump after "opening" the multi-gas ballast valve.
Be sure to follow this in order to prevent condensation of condensable gases within the Pump and thus extend its life.
In addition, after exhausting the condensable gases operate the Pump for about one hour while "opening" the multi-gas ballast valve.
(Depending on the situation of use, follow this procedure after confirming the appropriate hours of operation)
- When exhausting a large amount of condensable gases that could become liquidized within the Pump even though it is operated with the multi-gas ballast valve open, operate the Pump for about one hour while maintaining the multi-gas ballast valve "open" while opening the inlet port. (Depending on the situation of use, follow this procedure after confirming the appropriate hours of operation)
- The processing capacity of multi-gas ballast differs by the operating temperature of the Pump, as well as the according to the type and volume of condensable gases.
- To exhaust condensable gases (a mixture of water vapor, use the Pump after "opening" the multi-gas ballast valve.
- The ballast gas may not flow immediately after the multi-gas ballast valve is "opened."
When using the multi-gas ballast mechanism to exhaust condensable gases, start using the Pump after 10 minutes has elapsed.

7 Maintenance and Inspection

 **DANGER**

	<p>When conducting wiring and maintenance work, be sure to check that power is not supplied.</p> <p>* Otherwise, an electric shock could occur.</p>
---	---

 **WARNING**

	<p>These parts are hot during operation and could stay hot for a while after the Pump has stopped.</p> <p>Conduct maintenance work after the Pump has sufficiently cooled down while paying attention not to allow it to contact combustible objects or a human body.</p> <p>* Otherwise, fire or burns could occur.</p>
---	--

 **CAUTION**

	<p>Do not disassemble the enclosure.</p> <p>* Otherwise, the Pump could fail or diminish in performance.</p>
--	--

7.1 Daily Inspection

Check the Pump power source, intake pressure, back pressure, etc., on a regular basis to confirm that the Pump is operating under normal use conditions. If an ALARM lamp has turned ON or an error message is displayed by the operating panel LED, resolve the problem in accordance with "8. Troubleshooting."

- When a Pump error has occurred after taking appropriate actions to resolve the cause of the error, press the RESET switch on the panel or input a reset input signal (Pins No. 2-10) from the I/O connector (CN2). The error will be reset.

 **CAUTION**

	<p>If an error has occurred while operating the Pump using external signals, conduct maintenance and inspection after turning OFF the operation signal.</p> <p>* Otherwise, failures of devices as well as bodily injury could occur.</p>
---	---

When any abnormal conditions occur, other than the status bar alarm ON and operating panel LED display, resolve the problem in accordance with "8. Troubleshooting."

7.2 Intake /Exhaust Port Pipes

When inspecting and maintaining the intake and exhaust port pipes, pay attention to the following points.

- Be sure to stop the power supply.
- After washing the pipes, sufficiently dry them before installing.

⚠ WARNING



Be sure to conduct leak checks after the maintenance and inspection of pipes.
Conduct leak checks by pressurizing the pipes. Apply a pressure of 0.05MPa from the exhaust pipe.
* Otherwise, bodily injury could occur.

7.3 Lubricant

Check the amount of lubricant during daily inspection.

When checking the amount of lubricant, check it with an oil level gauge after disassembling the blank flange [1] of the pump cooling air discharge port side.

The oil level during Pump operation could be below the lower limit level. However, this is not an abnormal state.

Stop the Pump, wait for the oil level to become stable, and then check the oil level.

NOTICE

- If the oil level remains below the lower limit level after the Pump has stopped and the oil level is stable, the Pump could possibly fail. Contact the contact information at the end of this operating manual.

■ NeoDry7G

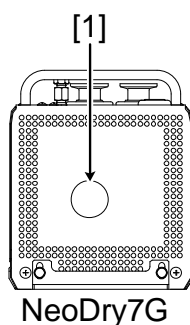

KA00075

Fig. 7.1

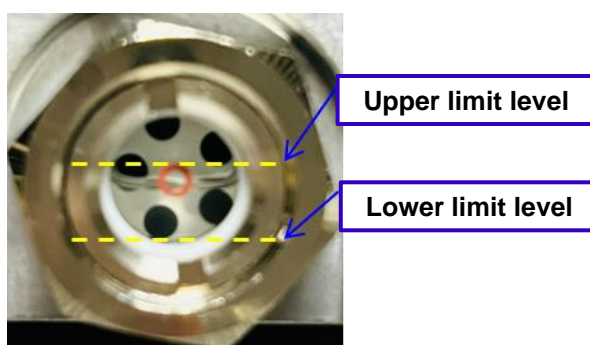
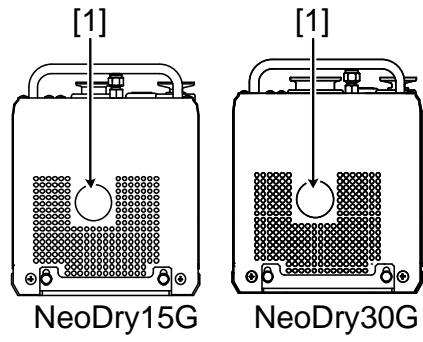

Photo 7.1

■ NeoDry15G · 30G



KA00056

Fig. 7.2

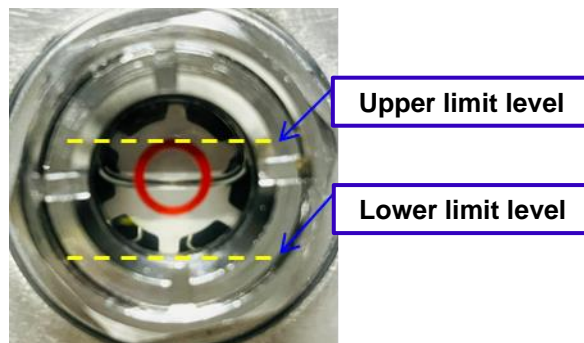

Photo 7.2

■ NeoDry36G

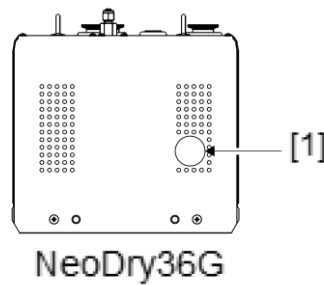

Fig. 7.3

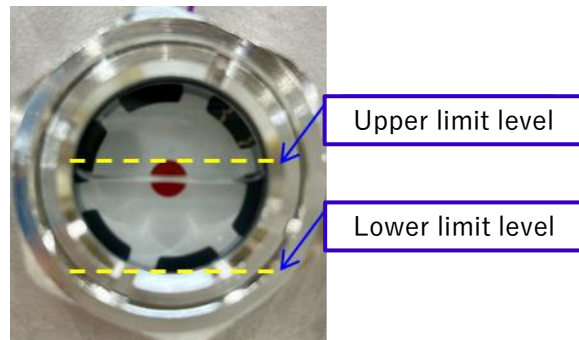

Photo 7.3

7.4 Overhaul

For safe Pump operation and to sustain required performance over a long time, pay attention to the following points:

- Operate the Pump within the range described in the catalogue and operating manual.
- Conduct maintenance and inspections based on "7. Maintenance and Inspection."
- Disassembling inspections and overhauls are services offered by Kashiyama and our certified dealers. We do not sell service parts.
- When returning the Pump, be sure to attach the Pump Return Form.
Refer to the contact information at the end of this operating manual in advance.
- For Pumps with special specifications, maintenance and inspection timing and procedures could differ. Please consult with us in advance.
- If a Pump will stop for a prolonged time (holiday or other reasons), stop the Pump and replace the gas inside it with an inert gas, such as N₂ and dry air. After drying the Pump sufficiently, seal the pump intake and exhaust ports with blank flanges immediately.

The following overhaul timing is recommended depending on usage.

Recommended overhaul timing	Example of usage
Every year to every other year (When the multi-gas ballast is used)	For use of condensable gases exhausting (water vapor, solvent mixed gases) (For solvent gas exhausting, to be consulted separately based on the type and volume of exhaustion)
Every 3 years	For clean gas exhausting (N ₂ gas, dry air)

The frequency of overhauls is determined by the conditions of use.

Moreover, depending on the type of solvent being taken in, an overhaul may be required within 1 year.



Contact the contact information at the end of this operating manual for servicing.

NOTICE

- When sending the Pump to us, first complete the Pump Return Form with all required information, including contaminants (gases used). Send the Pump Return Form to us before sending the Pump and devices.
- If the Pump has been used for exhausting condensable gases, send it after it has become fully dry.
- Depending on the type of exhaust gas used, it is harmful to disassemble or overhaul a Pump used for exhausting condensable gases, including solvents, as the residual gas is harmful. When sending it back to us, be sure to replace it completely with N₂ gas and seal the intake and exhaust ports with blank flanges, etc.

7.5 Pump Disassembling

When disassembling the Pump, confirm the following matters before doing so.

⚠ WARNING	
	<p>Do not enter the area below hoisted Pump.</p> <p>* Otherwise, bodily injury could be caused by a falling article.</p>
	<p>Pump lifting can only be conducted by personnel qualified for machine operation, including forklifts and cranes. Pay attention to safety. (For NeoDry36G only)</p> <p>* Otherwise, bodily injury could occur.</p>
	<p>Electric wiring shall only be conducted by qualified workers.</p> <p>* Otherwise, bodily injury and fire could occur.</p>
	<p>Before maintenance and inspection, remove the disconnecting device.</p> <p>* Otherwise, an electric shock could occur.</p>

⚠ CAUTION	
	<p>Do not lift the Pump by putting a belt on the handle.</p> <p>When lifting the Pump, two operators shall hold the handle by hand. (NeoDry7G, 15G, 30G)</p> <p>* Otherwise, bodily injury and failures of the Pump could occur.</p>

Refer to the following procedures when disassembling the Pump used.

■ **Procedures:**

- 1 Stop the Pump and replace the gas with an inert gas, such as N2 gas or dry air, depending on the type of exhaust gas.
- 2 Stop supplying power and remove the power cable.
- 3 Remove the intake port and intake port pipes, and seal the port with blank flanges.
- 4 Package it.

When loading and unloading NeoDry36G, lift it using the attached slinging equipment (M8 eyebolts). (Refer to "4.1 Installation")

7.6 Maintenance Standard

This Pump includes the parts (consumables) with limited lifespans.

Wear and deterioration of such consumables could advance over time and result in unstable operation. To maintain performance/features, periodic exchanges may be necessary.

For longer and stable use, these consumables need to be exchanged at certain intervals.

- The target exchange time varies according to the frequency and environment of use.
- For time of exchange, refer to the following table. The information provided here is simply a guideline.
Consumables may need to be exchanged earlier than the guidelines stated herein, depending on the conditions of use.
- Consumables need to be exchanged due to wear and deterioration. They are available at a cost, even before the Pump's warranty period has expired. Consumables can be exchanged only by the unit of exchange determined by Kashiyama.

Table 7.1 List of maintenance standard

Inspection/maintenance Items	Contents	Daily Inspection	Overhaul	Remarks
Daily Inspection	Inspection	○	-	Refer to Clause 7.1.
Intake/exhaust ports	Inspection	○	-	Refer to Clause 7.2.
Lubricant	Inspection	○	-	Refer to Clause 7.3.
	Exchange	-	○	Refer to Clause 7.4.(consumables)
Bearing	Exchange	-	○	Refer to Clause 7.4.(consumables)
A set of O-rings	Exchange	-	○	Refer to Clause 7.4.(consumables)
A set of shaft seals	Exchange	-	○	Refer to Clause 7.4.(consumables)
Anti-vibration rubber	Exchange	-	○	Refer to Clause 7.4.(consumables)
Wetted surface	Inspection	-	○	Refer to Clause 7.4, exchange it if needed (consumables)
A set of gears	Inspection	-	○	Refer to Clause 7.4, exchange it if needed (consumables)
Cooling fan	Inspection	-	○	Refer to Clause 7.4, exchange it if needed (consumables)
Electrical Parts	Inspection	-	○	Refer to Clause 7.4, exchange it if needed (consumables)
Normal performance check relevant to protection features	Inspection	-	○	Refer to Clause 7.4.

8 Troubleshooting

When trouble has occurred while using the Pump, follow the contents of the table on the following page for taking countermeasures.

 **DANGER**



When conducting wiring and maintenance work, be sure to check that power is not supplied.

* Otherwise, an electric shock could occur.

 **WARNING**



Electric wiring shall only be conducted by qualified workers.

* Otherwise, bodily injury and fire could occur.

Before maintenance and inspection, remove the disconnecting device.

* Otherwise, an electric shock could occur.

These parts are hot during operation and could stay hot for a while after the Pump has stopped.

Conduct maintenance work after the Pump has sufficiently cooled down while paying attention not to allow it to contact combustible objects or a human body.

* Otherwise, fire or burns could occur.

 **CAUTION**



Do not disassemble the enclosure.

* Otherwise, the Pump could fail or diminish in performance.

8.1 Basic Trouble

Table 8.1 List of details of errors

Abnormal cases	Cause	Countermeasure
Not starting	Power is not supplied.	Supply power.
	Pump error	Pump overhaul or exchange is necessary.
	Operating connectors are not installed.	In the case of direct-on-line operation, mount the operating connector to the I/O connector (CN2).
	Operating command selection has been changed.	Check the LED display codes "E581" and correctly set them appropriately.
Abnormal noise. Strong vibrations.	Articles are contacting the enclosure.	Remove the articles.
	Looseness of the enclosure setscrews.	Tighten the setscrews.
	Resonance of flexible pipes for air intake and discharge.	Fix the part causing the resonance.
	Damage to the Pump component parts.	Pump overhaul or exchange is necessary.
	Cooling fan error	Pump inspection and parts exchange required.
	Pump error	Pump overhaul or exchange is necessary.
Pressure at the inlet port does not decrease.	Air leaks from the intake side pipe.	Check the pipes.
	Pump error	Pump overhaul or exchange is necessary.
	Contamination within the Pump (such as moisture condensation)	The Pump needs to be overhauled.
	The multi-gas ballast valve is open	Close the multi-gas ballast valve.
Circuit breaker trips.	Circuit breaker capacity is insufficient.	Use recommended circuit breakers.
	Pump error	Pump overhaul or exchange is necessary.
	Motor error	Overhaul or exchange of the motor is necessary.
	Failure of power supply and wiring	Repair them.

* If a problem other than those mentioned above occurs, contact the contact information at the end of this operating manual.

8.2 When Pump Errors Occur

When a Pump error occurs, the following message is displayed on the operating panel LED display. In such cases, take appropriate countermeasures and then press the RESET switch on the operating panel. The error will be reset.

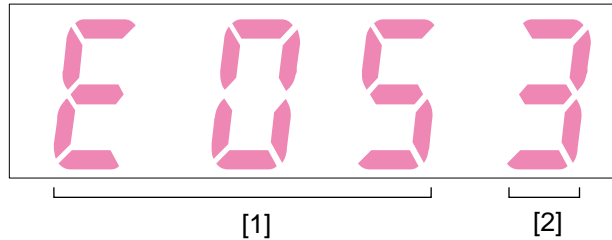

Fig. 8.1

KA00041

Table 8.2 Error contents on LED display

No.	LED display	Contents	Indication	State
[1]	First 3 digits	Content of Error	—	—
[2]	Last digit	State of error	0	—
			1	Under suspension
			2	In deceleration
			3	Running at constant speed
			4	In acceleration
			5	—
			6	When starting up
			7	—
			8	During overload control

Table 8.3 Causes and countermeasures of the error

LED display (First 3 digits)	Content of Error		Cause	Countermeasure
E01. □	Running at low speed	Overcurrent Protection	<ul style="list-style-type: none"> • Overload operation • Pump back pressure error 	<ul style="list-style-type: none"> • Check for clogged pipes on the exhaust port side. • The Pump needs to be overhauled. (Foreign objects could have entered the Pump)
E02. □	When decelerating			
E03. □	When accelerating			
E04. □	Miscellaneous			
E05. □	Overload protection			
E07. □	Overcurrent protection		<ul style="list-style-type: none"> • Rapid load fluctuations • Increase of supply voltage 	Check if the supply voltage has risen.
E08. □	EEPROM error		Internal memory error	Electrical components need to be inspected and repaired.
E09. □	Voltage shortage		Supply voltage error	Check if the supply voltage is sufficient or not.
E11. □	CPU error		Inverter error	Electrical components need to be inspected and repaired.
E19. □	Inverter temperature error		Inverter temperature rise	<ul style="list-style-type: none"> • Check that the ambient temperature is within the operating temperature range. • Electrical components need to be inspected and repaired. (The cooling fan could have stopped)
E35. □	Motor temperature error		Pump temperature rise	
E37. □	Thermostat error			
E38. □	Low-speed range overload protection		<ul style="list-style-type: none"> • Overload operation • Pump back pressure error 	<ul style="list-style-type: none"> • Check for clogged pipes on the exhaust port side. • The Pump needs to be overhauled. (Foreign objects could have entered the Pump)
E40. □	Operating panel communication error		Erroneous communication of operating panel	Electrical components need to be inspected and repaired.
E50. □	Start-time rotation error		<ul style="list-style-type: none"> • Shaft lock • Pump back pressure error 	<ul style="list-style-type: none"> • Check for clogged pipes on the exhaust port side. • The Pump needs to be overhauled. (Foreign objects could have entered the Pump)
E51. □	Speed deviation error		<ul style="list-style-type: none"> • Shaft lock • Motor rotation failure • Supply voltage error 	<ul style="list-style-type: none"> • The Pump needs to be overhauled. (Foreign objects could have entered the Pump) • Check if the supply voltage is sufficient or not.

LED display (First 3 digits)	Content of Error	Cause	Countermeasure
E 52. □	IPM temperature error	Inverter temperature rise	<ul style="list-style-type: none"> Check that the ambient temperature is within the operating temperature range. Electrical components need to be inspected and repaired. (The cooling fan could have stopped)
E 53. □	Thermistor disconnection error/Low temperature error	<ul style="list-style-type: none"> Thermistor disconnection/Use of Pump at an ambient temperature lower than the specified operating temperature 	<ul style="list-style-type: none"> Electrical components need to be inspected and repaired. Check that the ambient temperature is within the operating temperature range.
E 54. □	IPM error	<ul style="list-style-type: none"> Overload operation Supply voltage error 	<ul style="list-style-type: none"> The Pump needs to be overhauled. (Foreign objects could have entered the Pump) Check if the supply voltage is sufficient or not. Electrical components need to be inspected and repaired.
E 55. □	Reverse rotation error	Backflow of gas from the Pump exhaust port	Resolve the gas backflow condition from the Pump exhaust port
E 56. □	Motor stalling	Motor rotation failure	<ul style="list-style-type: none"> The Pump needs to be overhauled. (Foreign objects could have entered the Pump) Electrical components need to be inspected and repaired.
E 57. □	Electric current balance error	Motor current error	<ul style="list-style-type: none"> The Pump needs to be overhauled. (Foreign objects could have entered the Pump) Electrical components need to be inspected and repaired.

• * For checking of error contents, refer to Clause 5.2.3.

9 After-sales Services

9.1 Supply of Service Parts for Repair

9.1.1 Period of Availability

The period of availability is 7 years after the end of production of this Product.

During this period, we will always have service parts available and will supply them quickly.

However, there is a possibility that some parts such as electronic components cannot be supplied due to production termination by their manufacturers. In that case, please contact us for the availability of parts, price, delivery time, etc.

9.1.2 Parts That Have Reached the End of the Period of Availability

In principle, the supply of service parts that have reached the end of the period of availability will no longer be continued.

However, such parts could be supplied depending on the supplier's production situation or when there is large demand. Furthermore, Kashiyama will entertain the remanufacturing of the parts at the user's expense.

9.2 When Requesting Repairs

- We will repair it in accordance with the provisions of the warranty during the term of the warranty.
- When the term of the warranty has expired, Kashiyama will repair parts at customer's cost, if such parts can be used after repair.

9.3 Contact for Consultation

Contact the contact information at the end of this operating manual for service.

At this time, inform us of the Pump model and serial number.

10 Disposal Procedures

10.1 Precautions for Disposal

When disposing of the Pump, follow the rules and safety standards of the national government, local government, as well as the Act for the Promotion of Use of Recycled Resources,

11 Returning the Pump

When sending the Pump and peripheral devices to Kashiyama for the purpose of overhaul and repair, be sure to provide us with information of the gases used and products. These are required to follow the Industrial Safety and Health Act.

Before sending the devices to us, complete the Pump Return Form attached to this operating manual. Provide this to us by facsimile, email or mail. Depending on the type of gas used, we may ask users to send the devices to a designated supplier. This is necessary for smooth repair and overhaul.

Unless the return form is provided, returned devices could be deemed to be a dangerous object and receiving may be declined.

11.1 Returning Procedures

When returning the Pump, follow the following procedures.

- (1) Copy the Pump Return Form attached to the end of this operating manual and complete the form.
- (2) Depending on the type of exhaust gas, sufficiently dry the Pump after replacing the gas in it with an inert gas, such as N₂ gas and dry air. Apply the same procedures for peripheral devices to be returned. If disposal of the lubricant in the correct manner is possible, remove it fully.
- (3) Disassemble all accessory parts from the equipment.
- (4) Seal the intake and exhaust ports with blank flanges.
- (5) Place the Pump and these devices in thick polyethylene bags or wrap with polyethylene sheets to seal them as much as possible.
- (6) When returning the Pump or the units, place them on a wooden pallet with dimensions of 510 mm x 915 mm or smaller and fix them with string. If products are larger than the abovementioned pallet, contact the contact information at the end of this manual.
- (7) If products are not large enough to be fixed to a pallet, pack them in a rigid box.
- (8) If products to be returned are contaminated, follow the laws and regulations for transporting dangerous objects. Label the pallet or box to indicate that they are contaminated.
- (9) Complete the Pump Return Form at the end of this operating manual and provide it to us by facsimile, email or mail.
The Pump Return Form shall reach us before the products being returned.
- (10) Hand over the copy of the Pump Return Form to the forwarder. If the products being sent are contaminated, be sure to inform the forwarder of this.
- (11) Enclose the original copy of the Pump Return Form in an envelope and attach it to the outside of the package.

Pump Return Form

TO: Kashiyama Industries, Ltd.

Date:

ATTN: _____

<Pump return address>
4051-3 Negishi, Saku, Nagano Prefecture, 385-0062, Japar
Saku Minami Factory, Kashiyama Industries, Ltd.

Company Name _____
Dept.: _____
PIC _____
Phone #: _____
e-mail: _____

- 1. Shipping procedures** * Fill the pump with nitrogen gas and seal the intake and exhaust ports with blank flanges, etc.
* In winter, be sure to drain water from the cooling water pipes.
* It could become unbalanced as its gravity center is high. Securely package.
Provide the forwarder with above information.

- 2. Pump return information** For a better understanding of the state of the pump, please fill out the information below.
1) Send this to our sales representative via email or by fax.
2) When returning, attach the copy of this form to the pump.

Pump type			
Pump number			
Estimated date of return	Date: _____		
Reason for return	<input type="checkbox"/> Overhaul <input type="checkbox"/> Failure <input type="checkbox"/> Others ()		
	Details :		
Inspection ^{*1}	<input type="checkbox"/> Required <input type="checkbox"/> Not required		
Supply voltage and frequency	V	Hz	Electrical leaks possible <input type="checkbox"/> YES <input type="checkbox"/> NO
Power/Control wires removed	<input type="checkbox"/> YES <input type="checkbox"/> NO	Removed from	
Period of use	through _____		0 days:
Number of operating hours	As indicated by the hour meter or on the remote controller : _____ hrs.		
Name and process of equip. used			
Gas used (Substances remaining in the pump)	Substance Name	Chemical Symbol	Handling Precautions
Remarks			
Return exchanged parts ^{*2}	<input type="checkbox"/> YES <input type="checkbox"/> NO		
Preferred date of return	Date: _____		
Destination after repair	Department:		
	PIC:		Phone #:

- Note: 1. For safety, when returning the pump be sure to take measures to prevent gases inside from leaking.
2. Be sure to describe the gases used and any substances remaining in the pump.
3. We are unable to start operation without knowing what gases have been used.
4. The number of operating hours is important information. Provide this in as much detail as possible.
5. If the pump power/control wires have been disconnected, describe from where they have been disconnected.
*1. We may request an inspection fee from customers. For details, contact our service representative.
Prior to returning the pump, provide us with information on your requirements and conditions of use.
*2. If exchanged parts need to be returned, notify us in advance.
Depending on the parts to be returned, additional packaging and shipping charges may apply.
If there is no request for parts to be returned, we will assume that disposal of the parts has been accepted.

Hereby, we confirm the above matters, and that all relevant information has been provided.

Date: _____

Name of PIC: _____

Safety Data Sheet (lubricant)

SAFETY DATA SHEET

FOMBLIN® Y LVAC 25/6E

Revision Date 2022-08-15

SECTION 1: Identification of the substance/mixture and of the company/undertaking

1.1 Product identifier

- Trade name FOMBLIN® Y LVAC 25/6E

1.2 Relevant identified uses of the substance or mixture and uses advised against

Uses of the Substance/Mixture

- Lubricant
- For industrial use only

1.3 Details of the supplier of the safety data sheet

Company

SOLVAY SPECIALTY POLYMERS JAPAN K.K.
7TH FL, ATAGO GREEN HILLS MORI TOWER
ATAGO 2-5-1, MINATO-KU
105-6207, TOKYO
JAPAN
Tel: +81 3 5425 4790

E-mail address

sds.solvay@solvay.com

1.4 Emergency telephone number

0120 015 230 [Carechem 24] (toll-free, access from Japan only)

SECTION 2: Hazards identification

2.1 Classification of the substance or mixture

Classification (JIS Z 7252) and Hazard communication (JIS Z 7253) based on GHS.

- Not classified as hazardous product according to JIS Z 7252.

2.2 Label elements

Classification (JIS Z 7252) and Hazard communication (JIS Z 7253) based on GHS.

- No GHS labelling required according to JIS Z 7253.

2.3 Other hazards which do not result in classification

- Thermal decomposition can lead to release of toxic and corrosive gases.

SECTION 3: Composition/information on ingredients

3.1 Substance

P00000019891
Version : 1.10 / JP (EN)

www.solvay.com

1 / 12



SAFETY DATA SHEET

FOMBLIN® Y LVAC 25/6E

Revision Date 2022-08-15

- Not applicable, this product is a mixture.

3.2 Mixture

- Chemical nature Perfluoropolyethers containing additive

Information on Components and Impurities

Chemical name	CAS-No.	Number on official gazette	GHS Classification	Concentration [%]
Perfluorinated polyether	Confidential	Confidential	Not classified	>= 95
Perfluoropolyethers derivative	Confidential	Confidential	Not classified	<= 5

SECTION 4: First aid measures

4.1 Description of first aid measures

In case of inhalation

- Move to fresh air in case of accidental inhalation of fumes from overheating or combustion.
- Oxygen or artificial respiration if needed.

In case of skin contact

- Wash off with soap and water.

In case of eye contact

- Rinse immediately with plenty of water, also under the eyelids, for at least 15 minutes.
- If eye irritation persists, consult a specialist.

In case of ingestion

- Drink 1 or 2 glasses of water.
- Do NOT induce vomiting.
- If symptoms persist, call a physician.

4.2 Most important symptoms and effects, both acute and delayed

In case of inhalation

Effects

- No known effect.

In case of skin contact

Effects

- Effects of skin contacts may include:
- Redness

In case of eye contact

Effects

- Contact with eyes may cause irritation.
- Redness

In case of ingestion

Symptoms

- Ingestion may provoke the following symptoms:
- Nausea
- Vomiting
- Diarrhoea

4.3 Indication of any immediate medical attention and special treatment needed

P00000019891
Version : 1.10 / JP (EN)
www.solvay.com

2 / 12



SAFETY DATA SHEET

FOMBLIN® Y LVAC 25/6E

Revision Date 2022-08-15

Notes to physician

- None

SECTION 5: Firefighting measures

5.1 Extinguishing media

Suitable extinguishing media

- Water
- powder
- Foam
- Dry chemical
- Carbon dioxide (CO₂)

Unsuitable extinguishing media

- None

5.2 Special hazards arising from the substance or mixture

- The product is not flammable.
- Not explosive
- In case of fire hazardous decomposition products may be produced such as: Gaseous hydrogen fluoride (HF), Fluorophosgene

5.3 Advice for firefighters

Special protective equipment for firefighters

- Wear self-contained breathing apparatus and protective suit.
- When intervention in close proximity wear acid resistant over suit.

Further information

- Evacuate personnel to safe areas.
- Approach from upwind.
- Protect intervention team with a water spray as they approach the fire.
- Keep containers and surroundings cool with water spray.
- Keep product and empty container away from heat and sources of ignition.

SECTION 6: Accidental release measures

6.1 Personal precautions, protective equipment and emergency procedures

Advice for non-emergency personnel

- Prevent further leakage or spillage if safe to do so.

Advice for emergency responders

- Ensure adequate ventilation.
- Material can create slippery conditions.
- Sweep up to prevent slipping hazard.
- Keep away from open flames, hot surfaces and sources of ignition.

6.2 Environmental precautions

- Should not be released into the environment.
- Do not flush into surface water or sanitary sewer system.

6.3 Methods and materials for containment and cleaning up

- Soak up with inert absorbent material.
- Suitable material for picking up.

P00000019891
Version : 1.10 / JP (EN)

www.solvay.com

3 / 12



SAFETY DATA SHEET

FOMBLIN® Y LVAC 25/6E

Revision Date 2022-08-15

- Dry sand
- Earth
- Shovel into suitable container for disposal.

6.4 Reference to other sections

- Refer to protective measures listed in sections 7 and 8.

SECTION 7: Handling and storage

7.1 Precautions for safe handling

- Ensure adequate ventilation.
- Use personal protective equipment.
- Keep away from heat and sources of ignition.
- To avoid thermal decomposition, do not overheat.
- Take measures to prevent the build up of electrostatic charge.
- Clean and dry piping circuits and equipment before any operations.
- Ensure all equipment is electrically grounded before beginning transfer operations.

Hygiene measures

- Ensure that eyewash stations and safety showers are close to the workstation location.
- When using do not eat, drink or smoke.
- Wash hands before breaks and at the end of workday.
- Handle in accordance with good industrial hygiene and safety practice.

7.2 Conditions for safe storage, including any incompatibilities

Technical measures/Storage conditions

- Keep away from heat and sources of ignition.
- Keep in properly labelled containers.
- Keep away from combustible material.
- Keep away from incompatible products
- Provide tight electrical equipment well protected against corrosion.
- Refer to protective measures listed in sections 7 and 8.

Packaging material

- Suitable material**
- Plastic materials.

7.3 Specific end use(s)

- Contact your supplier for additional information

SECTION 8: Exposure controls/personal protection

8.1 Control parameters

- We are not aware of any national exposure limit.

SAFETY DATA SHEET

FOMBLIN® Y LVAC 25/6E

Revision Date 2022-08-15

Threshold limit values of by-products from thermal decomposition:

Components with official national occupational exposure limits

Components	Value type	Value	Basis
Hydrofluoric acid	ACL	0.5 ppm	Japan. Administrative Control Levels

Components with other national occupational exposure limits

Components	Value type	Value	Basis
Hydrofluoric acid	OEL-C	3 ppm 2.5 mg/m ³	Japan. The Japan Society for Occupational Health. Recommendation of Occupational Exposure Limits
		Skin absorption	

Components with other occupational exposure limits

Components	Value type	Value	Basis
Hydrofluoric acid	TWA	0.5 ppm	USA. ACGIH Threshold Limit Values (TLV)
		Danger of cutaneous absorption Expressed as :Fluorine	
Hydrofluoric acid	C	2 ppm	USA. ACGIH Threshold Limit Values (TLV)
		Danger of cutaneous absorption Expressed as :Fluorine	
Carbonyl difluoride	TWA	2 ppm	USA. ACGIH Threshold Limit Values (TLV)
Carbonyl difluoride	STEL	5 ppm	USA. ACGIH Threshold Limit Values (TLV)

8.2 Exposure controls

Control measures

Engineering measures

- Provide local ventilation appropriate to the product decomposition risk (see section 10).
- Refer to protective measures listed in sections 7 and 8.
- Apply technical measures to comply with the occupational exposure limits.

Individual protection measures

Respiratory protection

- In case of decomposition (see section 10), use an air breathing apparatus with face mask.
- Use only respiratory protection that conforms to international/ national standards.

Hand protection

- Wear protective gloves.

Suitable material

- Nitrile rubber
- PVC
- Neoprene gloves
- butyl-rubber

- Take note of the information given by the producer concerning permeability and break through times, and of special

P0000019891
Version : 1.10 / JP (EN)
www.solvay.com



SAFETY DATA SHEET

FOMBLIN® Y LVAC 25/6E

Revision Date 2022-08-15

workplace conditions (mechanical strain, duration of contact).

Eye protection

- Tightly fitting safety goggles

Skin and body protection

- Wear work overall and safety shoes.

Hygiene measures

- Ensure that eyewash stations and safety showers are close to the workstation location.
- When using do not eat, drink or smoke.
- Wash hands before breaks and at the end of workday.
- Handle in accordance with good industrial hygiene and safety practice.

Environmental exposure controls

- Dispose of rinse water in accordance with local and national regulations.

SECTION 9: Physical and chemical properties

9.1 Information on basic physical and chemical properties

<u>Physical state</u>	liquid
<u>Colour</u>	colourless
<u>Odour</u>	odourless
<u>Odour Threshold</u>	No data available
<u>Melting point/freezing point</u>	<u>Melting point/range:</u> Not applicable
<u>Initial boiling point and boiling range</u>	<u>Boiling point/boiling range:</u> > 290 °C
<u>Flammability (solid, gas)</u>	No data available
<u>Flammability (liquids)</u>	The product is not flammable.
<u>Flammability/Explosive limit</u>	No data available
<u>Flash point</u>	The product is not flammable.
<u>Auto-ignition temperature</u>	No data available
<u>Decomposition temperature</u>	> 250 °C
<u>pH</u>	No data available
<u>Viscosity</u>	<u>Viscosity, dynamic :</u> 579 mPa.s
<u>Solubility</u>	<u>Water solubility:</u> insoluble <u>Solubility in other solvents:</u> Fluorinated solvents: soluble
<u>Partition coefficient: n-octanol/water</u>	No data available
<u>Vapour pressure</u>	< 0.000001 hPa (20 °C)
<u>Density</u>	1.90 g/cm ³

P00000019891
Version : 1.10 / JP (EN)
www.solvay.com

6 / 12



SAFETY DATA SHEET

FOMBLIN® Y LVAC 25/6E

Revision Date 2022-08-15

Relative density	No data available
Relative vapor density	No data available
Particle characteristics	No data available
Evaporation rate (Butylacetate = 1)	No data available

9.2 Other information

Oxidizing properties	Not considered as oxidizing
Impact sensitivity	Not explosive
Molecular weight	3,300 Da Polymer Molar Mass

SECTION 10: Stability and reactivity

10.1 Reactivity

- No dangerous reaction known under conditions of normal use.

10.2 Chemical stability

- Stable under recommended storage conditions.
- Metals promote and lower decomposition temperature

10.3 Possibility of hazardous reactions

- No dangerous reaction known under conditions of normal use.

10.4 Conditions to avoid

- Avoid to use in presence of high voltage electric arc and in absence of oxygen.
- Keep away from flames.
- To avoid thermal decomposition, do not overheat.

10.5 Incompatible materials

- Alkali metals
- Lewis acids (Friedel-Crafts) above 100°C
- Aluminum and magnesium in powder form above 200°C

10.6 Hazardous decomposition products

- Gaseous hydrogen fluoride (HF).
- Fluorophosgene

SECTION 11: Toxicological information

11.1 Information on toxicological effects

Acute toxicity

Acute oral toxicity

Perfluorinated polyether

LD50 : > 15,000 mg/kg - Rat , male and female
Test substance: Molecular weight ~ 3200

Not classified as hazardous for acute oral toxicity according to GHS.

No significant adverse effects were reported

Unpublished internal reports

LD50 : > 5,000 mg/kg - Rat

No data available

Perfluoropolyethers derivative

Acute inhalation toxicity

Acute dermal toxicity

P00000019891
Version : 1.10 / JP (EN)

www.solvay.com

7 / 12



SAFETY DATA SHEET

FOMBLIN® Y LVAC 25/6E

Revision Date 2022-08-15

Perfluorinated polyether	LD50 : > 5,000 mg/kg - Rat , male and female Test substance: Molecular weight ~ 3200 Not classified as hazardous for acute dermal toxicity according to GHS. No effect observed at this dose or concentration Unpublished internal reports
Perfluoropolyethers derivative	LD50 : > 2,000 mg/kg - Rat
Acute toxicity (other routes of administration)	
Perfluorinated polyether	LD50 : > 5,000 mg/kg - Rat , for males and females Intraperitoneal route Test substance: Molecular weight ~ 3200 Unpublished reports

Skin corrosion/irritation

Perfluorinated polyether	Rabbit Not classified as irritating to skin Test substance: Molecular weight ~ 3200 Unpublished internal reports 2 Weeks - Rabbit No skin irritation Method: Repeated dermal application test. Test substance: Molecular weight ~ 3200 Unpublished internal reports
Perfluoropolyethers derivative	Rabbit slight irritation

Serious eye damage/eye irritation

Perfluorinated polyether	Rabbit Not classified as irritating to eyes Test substance: Molecular weight ~ 3200 Unpublished internal reports
Perfluoropolyethers derivative	Rabbit slight irritation

Respiratory or skin sensitisation

Perfluorinated polyether	Maximisation Test - Guinea pig Does not cause skin sensitisation. Test substance: Molecular weight ~ 3200 Unpublished internal reports Respiratory sensitization No information available.
Perfluoropolyethers derivative	Buehler Test - Guinea pig Did not cause sensitisation on laboratory animals. Dermal

Mutagenicity

Genotoxicity in vitro

Perfluorinated polyether	Ames test with and without metabolic activation negative Test substance: Molecular weight ~ 3200 Unpublished internal reports
Perfluoropolyethers derivative	Not mutagenic in Ames Test

Genotoxicity in vivo

No data available

Carcinogenicity

No data available

Toxicity for reproduction and development

Toxicity to reproduction/Fertility	No data available
Developmental Toxicity/Teratogenicity	No data available

STOT

STOT - single exposure

P00000019891
Version : 1.10 / JP (EN)

www.solvay.com

8 / 12



SAFETY DATA SHEET

FOMBLIN® Y LVAC 25/6E

Revision Date 2022-08-15

Perfluorinated polyether	The substance or mixture is not classified as specific target organ toxicant, single exposure according to GHS criteria.
STOT - repeated exposure Perfluorinated polyether Perfluorinated polyether	The substance or mixture is not classified as specific target organ toxicant, repeated exposure according to GHS criteria. Oral 28-day - Rat , male and female NOEL: 1000 mg/kg Test substance: Molecular weight ~ 3200 no systemic effect observed Unpublished internal reports No data available
<u>Experience with human exposure</u> <u>CMR effects</u>	No data available
Mutagenicity Perfluorinated polyether <u>Aspiration toxicity</u> <u>Further information</u>	Not mutagenic in Ames Test No data available Description of possible hazardous to health effects is based on experience and/or toxicological characteristics of several components. Thermal decomposition can lead to release of toxic and corrosive gases. The exposure to decomposition products causes severe irritation of eyes, skin and mucous membranes.

SECTION 12: Ecological information

12.1 Toxicity

Aquatic Compartment

Acute toxicity to fish

Perfluorinated polyether By analogy
No toxicity at the limit of solubility

Acute toxicity to daphnia and other aquatic invertebrates

Perfluorinated polyether By analogy
No toxicity at the limit of solubility

Perfluoropolyethers derivative EC50 - 48 h : > 100 mg/l - Daphnia magna (Water flea)

Toxicity to aquatic plants No data available

Toxicity to microorganisms No data available

Chronic toxicity to fish No data available

Chronic toxicity to daphnia and other aquatic invertebrates No data available

12.2 Persistence and degradability

Abiotic degradation

No data available

Physical- and photo-chemical elimination

No data available

Biodegradation

No data available

Degradability assessment

Perfluorinated polyether The product is not considered to be rapidly degradable in the environment

12.3 Bioaccumulative potential

P0000019891
Version : 1.10 / JP (EN)
www.solvay.com



SAFETY DATA SHEET

FOMBLIN® Y LVAC 25/6E

Revision Date 2022-08-15

Partition coefficient: n-octanol/water	No data available
Bioconcentration factor (BCF)	No data available
12.4 Mobility in soil	
Adsorption potential (Koc)	No data available
Known distribution to environmental compartments	No data available
12.5 Results of PBT and vPvB assessment	No data available
12.6 Other adverse effects	
Ecotoxicity assessment	
Short-term (acute) aquatic hazard Perfluorinated polyether	No toxicity at the limit of solubility
Remarks	Ecological injuries are not known or expected under normal use.

SECTION 13: Disposal considerations

13.1 Waste treatment methods

Product Disposal

- Can be incinerated, when in compliance with local regulations.
- The incinerator must be equipped with a system for the neutralisation or recovery of HF.
- Dispose of in accordance with local regulations.

Advice on cleaning and disposal of packaging

- Empty containers can be landfilled, when in accordance with the local regulations.

SECTION 14: Transport information

Local regulation

not regulated

International transport regulations

IMDG

not regulated

IATA

not regulated

Note: The above regulatory prescriptions are those valid on the date of publication of this sheet. Given the possible evolution of transport regulations for hazardous materials, it would be advisable to check their validity with your sales office.

SECTION 15: Regulatory information

15.1 Safety, health and environmental regulations/legislation specific for the substance or mixture

ISHL Substances Subject to be Notified Names Not relevant

P00000019891
Version : 1.10 / JP (EN)
www.solvay.com

10 / 12



SAFETY DATA SHEET

FOMBLIN® Y LVAC 25/6E

Revision Date 2022-08-15

Poisonous and Deleterious Substances Control Law Not relevant

Act on Confirmation, etc. of Release Amounts of Specific Chemical Substances in the Environment and Promotion of Improvements to the Management Thereof Not relevant

Notification status

Inventory Information	Status
United States TSCA Inventory	- On or in compliance with the active portion of the TSCA inventory - One or more components is/are in Low Volume Exemption (LVE). - Use restricted to lubricant - No spray applications are permitted. - No consumer applications are allowed.
Canadian Domestic Substances List (DSL)	- One or more components not listed on inventory
Canadian Non-Domestic Substances List (NDSL)	- One or more components not listed on inventory
Australia Inventory of Chemical Substances (AICS)	- One or more components not listed on inventory
Korea. Korean Existing Chemicals Inventory (KECI)	- Listed on Inventory
China. Inventory of Existing Chemical Substances in China (IECSC)	- Listed on Inventory
Japan. ISHL - Inventory of Chemical Substances	- Listed on Inventory
Japan. CSCL - Inventory of Existing and New Chemical Substances	- In compliance with the inventory
Philippines Inventory of Chemicals and Chemical Substances (PICCS)	- One or more components not listed on inventory
New Zealand. Inventory of Chemical Substances	- One or more components not listed on inventory
Taiwan. Chemical Substance Inventory (TCSI)	- Listed on Inventory
EU. European Registration, Evaluation, Authorization and Restriction of Chemical (REACH)	- If product is purchased from Solvay in Europe it is in compliance with REACH, if not please contact the supplier.

SECTION 16: Other information

Key or legend to abbreviations and acronyms used in the safety data sheet

- ACL: Administrative Control level
- C: Ceiling limit
- OEL-C: Occupational Exposure Limit-Ceiling
- STEL: Short-term exposure limit
- TWA: 8-hour, time-weighted average
- ADR: European Agreement on International Carriage of Dangerous Goods by Road.

P00000019891
Version : 1.10 / JP (EN)

www.solvay.com

11 / 12



SAFETY DATA SHEET

FOMBLIN® Y LVAC 25/6E

Revision Date 2022-08-15

- ADN: European Agreement on the International Carriage of Dangerous Goods by Inland Waterways.
- RID: European Agreement concerning the International Carriage of Dangerous Goods by Rail.
- IATA: International Air Transport Association.
- ICAO-TI: Technical Instructions for Safe Transport of Dangerous Goods by Air.
- IMDG: International Maritime Dangerous Goods.
- TWA: Time weighted average
- ATE: Estimated value of acute toxicity
- EC: European Community number
- CAS: Chemical Abstracts Service.
- LD50: Substance that causes 50% (half) death in the test animals group (Median Fatal Dose).
- LC50: Substance concentration causing 50% (half) death in the test animals group.
- EC50: Effective Concentration of the substance causing the maximum of 50%.
- PBT: Persistent, Bioaccumulative and Toxic substance.
- vPvB: Very Persistent and Very Bioaccumulative.
- GHS/CLP/SEA: Classification, labeling, packaging regulation
- DNEL: Derived No Effect Level
- PNEC: Predicted No Effect Concentration
- STOT: Specific Target Organ Toxicity

Not all acronyms listed above are referenced in this SDS.

The information provided in this Safety Data Sheet is correct to the best of our knowledge, information and belief at the date of its publication. Such information is only given as a guidance to help the user handle, use, process, store, transport, dispose and release the product in satisfactory safety conditions and is not to be considered as a warranty or quality specification. It should be used in conjunction with technical sheets but do not replace them. Thus, the information only relates to the designated specific product and may not be applicable if such product is used in combination with other materials or in any other manufacturing process, unless otherwise specifically indicated. It does not release the user from ensuring he is in conformity with all regulations linked to its activity.

EC Declaration of Conformity

Doc No: DCMER-097E

EC DECLARATION OF CONFORMITY

We, KASHIYAMA INDUSTRIES, LTD.

1-1 Nenei, Saku City, Nagano 385-8511 Japan

declare in our sole responsibility that the following product conforms to the Essential Health and Safety Requirements of the directives and standards described below.

Product : Dry Vacuum Pump
Models : NeoDry7G, NeoDry15G, NeoDry30G, NeoDry36G

to which this declaration relates complies with the provisions of following European Directives:

Machinery Directive 2006/42/EC
EMC Directive 2014/30/EU
RoHS Directive 2011/65/EU as amended by (EU) 2015/863

Applied Harmonized Standards:

EN ISO 12100:2010

Safety of machinery – General principles for design - Risk assessment and risk reduction

IEC/EN 61010-1, 3rd Edition

Safety requirements for electrical equipment for measurement, control and laboratory use - Part 1: General requirements

EN ISO 13849-1:2015

Safety of machinery - Safety-related parts of control systems - Part 1: General principles for design

EN ISO 13849-2:2012

Safety of machinery - Safety-related parts of control systems - Part 2: Validation

EN 1012-2:1996+A1:2009

Compressors and vacuum pumps - Safety requirements - Part 2: Vacuum pumps

EN 61326-1:2013 / IEC 61326-1:2020

Electrical equipment for measurements, control and laboratory use - EMC requirements
- Part 1: General requirements (Class B).

EN IEC 63000:2018

Technical documentation for the assessment of electrical and electronic products with respect to the restriction of hazardous substances

Unauthorized modifications of the machinery will cancel this declaration.

Importer in Europe:

Company : Kashiyama Europe GmbH
Address : Leopoldstrasse 244, 80807 Munich, Germany

The authorized signatory to this declaration:

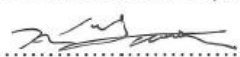
Name : Kunihiko Yamaura
Company : Kashiyama Industries, Ltd.
Title : General Manager
Engineering Department R&D Division II Vacuum Division
Address : 1-1 Nenei, Saku City, Nagano 385-8511 Japan Nagano Japan
Signature :  Place and Date : 27. March. 2023

Management responsibility person of the TD(Technical Documentation):

Name : Makoto Tomioka
Company : Kashiyama Industries, Ltd.
Title : Deputy General Manager
Engineering Department R&D Division II Vacuum Division
Address : 1-1 Nenei, Saku City, Nagano 385-8511 Japan
Signature :  Place and Date : Nagano Japan 27. March. 2023

UK Declaration of Conformity

Doc No: DCMER-097U

UK DECLARATION OF CONFORMITY

We, KASHIYAMA INDUSTRIES, LTD.

1-1 Nenei, Saku City, Nagano 385-8511 Japan

declare in our sole responsibility that the following product conforms to the Essential Health and Safety Requirements of the regulations and standards described below.

Product : Dry Vacuum Pump
Models : NeoDry7G, NeoDry15G, NeoDry30G, NeoDry36G

to which this declaration relates complies with the provisions of following UK Regulations:

S.I. 2008/1597 Supply of Machinery (Safety) Regulations 2008
S.I. 2016/1091 Electromagnetic Compatibility Regulations 2016
S.I. 2012/3032 The Restriction of the Use of Certain Hazardous Substances in Electrical and Electronic Equipment Regulations 2012

Applied Designated Standards:

BS EN ISO 12100:2010

Safety of machinery – General principles for design - Risk assessment and risk reduction

BS EN 61010-1:2010+A1:2019

Safety requirements for electrical equipment for measurement, control, and laboratory use - Part 1: General requirements

BS EN ISO 13849-1:2015

Safety of machinery - Safety-related parts of control systems - Part 1: General principles for design

BS EN ISO 13849-2:2012

Safety of machinery - Safety-related parts of control systems - Part 2: Validation

BS EN 1012-2:1996+A1:2009

Compressors and vacuum pumps - Safety requirements - Part 2: Vacuum pumps

BS EN 61326-1:2013 / IEC 61326-1:2020

Electrical equipment for measurements, control and laboratory use - EMC requirements
- Part 1: General requirements (Class B).

BS EN IEC 63000:2018

Technical documentation for the assessment of electrical and electronic products with respect to the restriction of hazardous substances

Unauthorized modifications of the machinery will cancel this declaration.

Importer in Europe:

Company : Kashiyama Europe GmbH
Address : Leopoldstrasse 244, 80807 Munich, Germany

The authorized signatory to this declaration:

Name : Kunihiro Yamaura
Company : Kashiyama Industries, Ltd.
Title : General Manager
Engineering Department R&D Division II Vacuum Division

Address : 1-1 Nenei, Saku City, Nagano 385-8511 Japan

Signature :  **Place and Date : Nagano Japan**
27 March 2023

Management responsibility person of the TD(Technical Documentation):

Name : Makoto Tomioka
Company : Kashiyama Industries, Ltd.
Title : Deputy General Manager
Engineering Department R&D Division II Vacuum Division

Address : 1-1 Nenei, Saku City, Nagano 385-8511 Japan

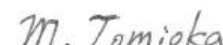
Signature :  **Place and Date : Nagano Japan**
27 March 2023

Kashiyama
Vacuum Solutions